

**ISSN 1454-9174**



**ANNALS  
OF THE  
UNIVERSITY OF PETROȘANI**

**MINING  
ENGINEERING**

**vol. 17 (XLIV)**

**UNIVERSITAS PUBLISHING HOUSE  
Petroșani – ROMÂNIA, 2016**

---

**EDITOR OF PUBLICATION**  
**Prof. PhD.eng. Ioan-Lucian BOLUNDUT**

---

**ADVISORY AND EDITORIAL BOARD OF MINING ENGINEERING  
ISSUES**

**ADVISORY BOARD**

Prof. PhD. Eng. Zacharis AGIOTANTIS	Technical University of Crete - Greece
PhD. Habil.Eng. Marwan AL HEIB	Ecole des Mines de Nancy, INERIS, France
PhD. Eng. Horea BENDEA	Politecnico di Torino, Italy
Prof. PhD. Eng. Raimondo CICCÙ	University of Cagliari, Italy
Prof. PhD. Eng. Carsten DREBENSTEDT	Technische Universität Bergakademie Freiberg – Germany
PhD. Eng. Edmond GOSKOLLI	National Agency of Natural Resources, Albania
Prof. PhD. Eng. Victor HARCENKO	Moscow State Mining University Russia
Assoc. Prof. PhD. Eng. Ventzislav IVANOV	University of Mining and Geology – Sofia - Bulgaria
Assoc. Prof. PhD. Eng. Charles KOCSIS	University of Nevada, Reno, U.S.A
Prof. PhD. Eng. Andrei KORCEAK	Moscow State Mining University Russia
Prof. PhD. Eng. Gheorghe MORARU	Technical University of Moldova – Chișinău, Moldova
Prof. PhD. Eng. Roland MORARU	University of Petroșani
Prof. Ph.D. Eng. Jan PALARSKI	Silesian University of Technology, Gliwice, Poland
PhD. Eng. Raj SINGHAL	Int. Journal of Mining, Reclamation and Environment - Canada
Prof. PhD. Eng. Ingo VALMA	Tallin University of Technology – Estonia
Prof. PhD. Eng. İşik YILMAZ	Cumhuriyet University – Istanbul, Turcia

**EDITORIAL BOARD**

Editor-in-chief:	Prof. PhD. Eng. Ilie ONICA	University of Petroșani
Deputy editors:	Lecturer PhD. Eng. Dacian-Paul MARIAN Assoc. Prof. PhD. Gabriela DUMBRAVĂ	University of Petroșani University of Petroșani
Associate editors:	Prof. PhD. Eng. Victor ARAD Assoc. Prof. PhD. Eng. Camelia BĂDULESCU Prof. PhD. Eng. Eugen COZMA Prof. PhD. Eng. Ioan DUMITRESCU Assoc. Prof. PhD. Eng. Emilia DUNCA Prof. PhD. Eng. Dumitru FODOR Prof. PhD. Eng. Mircea GEORGESCU Assoc. Prof. PhD. Eng. Tudor GOLDAN Lecturer PhD. Eng. Ladislau RADERMACHER Prof. PhD. Eng. Ilie ROTUNJANU Assoc. Prof. PhD. Eng. Mihaela TODERAȘ Assoc. Prof. PhD. Eng. Ioel VEREȘ	University of Petroșani University of Petroșani University of Petroșani University of Petroșani University of Petroșani University of Petroșani University of Petroșani University of Petroșani University of Petroșani University of Petroșani University of Petroșani University of Petroșani University of Petroșani University of Petroșani

---

**Editorial office address:** University of Petroșani, 20 University Street, 332006, Petroșani, Romania, Phone: (40) 254/54.29.94, 54.25.80, 54.25.81, 54.25.82, 54.97.49, Fax. (40) 254/54.34.91, 54.62.38, www.upet.ro, E-mail: ibol@upet.ro

---

## CONTENTS

FECHET, R.M., DEAK, Ș.E. - <i>The Importance of Mineralogical-Petrographic Diagnoses of Clay Deposits in the Cement Industry</i> .....	5
FECHET, R.M., MOANȚĂ, A., DEAK, Ș.E., PETRE, I. - <i>Types of Hard Rocks in the Raw Material Deposits for the Cement Industry</i> .....	13
RĂDOI, F. - <i>Closing Solutions Applied to Mines in Jiu Valley</i> .....	23
CHIUZAN, E., CIOCLEA, D., MATEI, A., GHERGHE, I., BOANTĂ, C., TOMESCU, C. - <i>Reclassification of Praid Salt Mine by the Rate of Gas Emission</i> .	31
GHERGHE, I. - <i>Functional Parameters Analysis of Industrial Ventilation Installations</i> .....	37
FAUR, F., LAZĂR, M., ANDRAȘ, I. - <i>Research Regarding Fertilization of Mining Waste Dumps by Using Sewage Sludge. Case Study for Motru Area</i> .....	47
APOSTU (NYARI), I.M., LAZĂR, M., FAUR, F. - <i>Implementation of Sustainable Practices in the Lignite Open Pit Rosia de Jiu</i> .....	59
MARIAN, R.R. - <i>Surface Subsidence Prognosis in the Case of Lonea Mine Using Knothe Budryk Influence Function</i> .....	69
VEREȘ, I. - <i>Determination of Geodesic Points in Cases of Indetermination</i> .....	81
MARIAN, D.P., MARIAN, R.R. - <i>Performing Some Analysis on DEM Using the Surfer Software</i> .....	91
<i>Index of authors</i> .....	100
<i>Instructions for authors</i> .....	101
<i>Scientific reviewers</i> .....	103



## THE IMPORTANCE OF MINERALOGICAL- PETROGRAPHIC DIAGNOSES OF CLAY DEPOSITS IN THE CEMENT INDUSTRY

ROXANA MAGDALENA FECHET<sup>1</sup>  
ȘTEFANIA ELENA DEÁK<sup>1</sup>

**Abstract:** *By identifying the crystalline phases, microscopic analysis provides data on the mineralogical composition of deposits. In individual cases, the optical microscopy may exceed as utility other analysis, the mineralogical - petrographic diagnosis being the main way which can emphasize in the deposits those rocks with adverse effects on the technological process. In this paper such case refers to a clay deposit used as raw material in cement industry. The results of optical microscopy analysis revealed, in addition to the clay and allogenic and authigenic constituents structure, the manner that the rocks were affected by the diagenesis.*

**Keywords:** *optical microscopy, clay, micro-stratification, structure, diagenesis*

### 1. INTRODUCTION

Optical microscopy is a non-invasive method of investigation, [1], [2], with applications in mineralogical and petrographic characterization of different types of rocks in the deposits. It has as main advantage that once captured an image; this can be stored and analyzed later to determine certain physical and optical characteristics, such as crystal size, contour, color, macles, cleavage, mineral isotropy and anisotropy, birefringence, extinction. Data analysis can provide an advance determination of other important mechanical characteristics such as grinding capacity, mechanical strengths, freeze - thaw resistance etc.

This technique was used to investigate the mineralogical and petrographic characteristics of different types of rocks from a clay deposit, mineralogical - petrographic diagnosis being the main way which can emphasizes in the deposits those rocks with adverse effects on the technological process. This paper presents the investigation results of a clay deposit for the cement industry, as a case study. The deposit bedrock is composed of Mesozoic ophiolites and the cover of Cretaceous sedimentary formations (Barremian - Aptian, Turonian - Senonian) and Quaternary. The deposit outlined in inferior Barremian - Aptian deposits is constituted mostly of

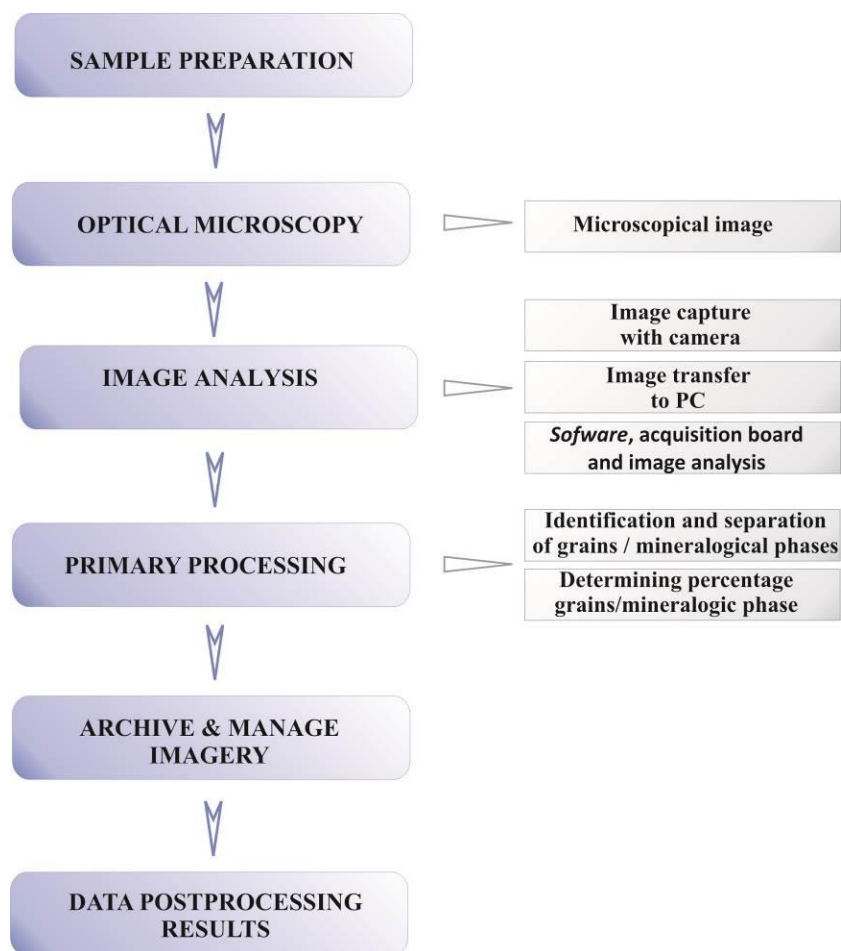
---

<sup>1</sup> *PhD, Senior Researcher, CEPROCIM S.A.*

shale colored in gray - blackish to black - violet, and at the top shows a layer of clay brown - yellowish and reddish assigned by Quaternary, [3].

## 2. METHODOLOGY

The following steps are necessary for optical microscopy analysis: sample preparation, image capture - acquisition - image processing, image analysis, data processing and interpretation, Figure 1.



**Figure 1.** Mineralogical characteristics of sandstones (allogenic constituents)

For the microscopic images capture was used a video camera Philips, with the following technical characteristics: C and CS½ mount, 0.2 lux sensitivity, geometric resolution of  $512 \times 512$  pixels, manually adjustable amplification, BNC connector link.

### 3. IMPORTANT MINERALOGICAL CHARACTERISTICS FOR PETROGRAPHIC DIAGNOSIS OF ARGILLACEOUS ROCKS

As 'argillaceous minerals' are typically described the aluminum hydroxy silicates crystallized in monoclinic system, mainly present in the argillaceous rocks composition.

#### 3.1 Common characteristics

The common properties of the group are:

- layered structure by combining two cationic levels (cationic units) in a reticular plan: the tetrahedral level and octahedral level,
- very small sizes (less than  $2\mu$ ), size of the colloidal particles forming lamellar aggregates with the possibility of water retention between the reticular planes,
- usually appearance in the form of intimate mixtures of different mineralogical phases.

The clay minerals also present some characteristic properties influenced by:

- variable distance between the reticular planes and, as a consequence, specific basal reflections,
- dewatering property, reaction to heating, and resulted decomposition products,
- basic ion exchange capacity in the spaces between reticular planes,
- water and organic compounds absorbability that cause expansion (swelling) and various specific color reactions,
- infrared absorption.

#### 3.2 Optic properties and crystal shape

The argillaceous minerals properties also include the optic characteristics and crystal shape. Using the polarizing microscope is not always satisfactory because of the very small size crystals and due to ingress of liquids immersion interlayer spaces. However, using the high magnification lenses on the largest mineral crystals, the optical microscopy allows observing the index of refraction, color, birefringence and even  $2V$  angle. Of these parameters, the index of refraction is the most variable and may be influenced by temperature, water content, the presence of  $Fe_2O_3$  and the number of expandable ayers in the mineral structure. For this investigation, the index of refraction average value is usually estimated, [4].

### 3.3 Mineralogical characteristics

By decomposition of some erosion minerals, especially the feldspars and iron and magnesium silicate, new minerals can occur, as kaolinite, montmorillonite, limonite, boehmite. These new minerals usually compose the bulk of the most clay types. Some of the sediment clays are represented only by relict minerals, as quartz, mica, feldspar and argillaceous minerals from underlying clay rocks as illite and hydromica. The most common authigenic minerals in clay deposits are calcite, opal, chalcedony, pyrite, glauconite, chlorite and illite. The last two are formed especially in marine environment by diagenetic alteration of detrital clays, [4].

In terms of chemical composition, silica predominate the clay rocks and is part of all argillaceous minerals and their authigenic products. Aluminum oxide is a base component of clay minerals, secondary silicates and unaltered silicates. Calcium oxide in the clay appears mainly as carbonates; however in some shales the calcium oxide exceeds the necessary quantity for carbonates development. Magnesium oxide appears in silicates, carbonates and some unaltered silicates.

Optical microscopy determination of mineralogical composition, texture and structure, petrographic diagnosis of clay rocks, as well as those associated with them, is most often an advantage. Textural and structural characteristics of clays are represented by size and mineralogical nature of the components. Usually, the clay structure variety is difficult to be identified.

The clay structure is most frequent characterized by well marked compactness and stratification, due to the followings conditions:

- alternating layers of different particle sizes, aleurites and pelites,
- alternating darker with lighter coloured layers, due to various organic matter content,
- alternating richer and poorer calcite layers.

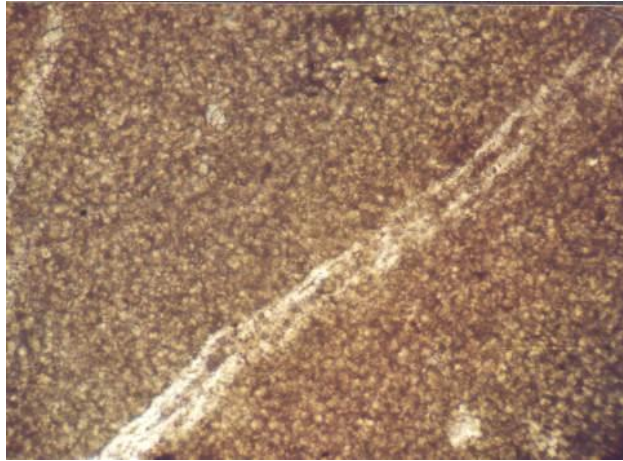
The optical microscopy identifies a micro-bedding usually due to seasonal fluctuation in the input of some material, in specific precipitation conditions of a certain material, etc. The flows may also have an influence in creating of these aspects. The main element that introduces variations in the general aspect of micro-bedding is the more important participation of a coarse clastic material. Some diagenetic and epigenetic formations can give the structure specific characters, as the case, [5].

A particular case is illustrated by residual rocks, where can often occur for relict formations. They can be derived either from massive rocks or pyroclastic rocks. Argillaceous rocks can show synergic deformation structures, such folding and brecciation. For strengthened, compact clays, due to compaction and recrystallization, bounding surfaces occur, as a consequence of development and distribution manner of the micaceous elements. They do not correspond to the bedding surfaces and are called cleavage, [6].

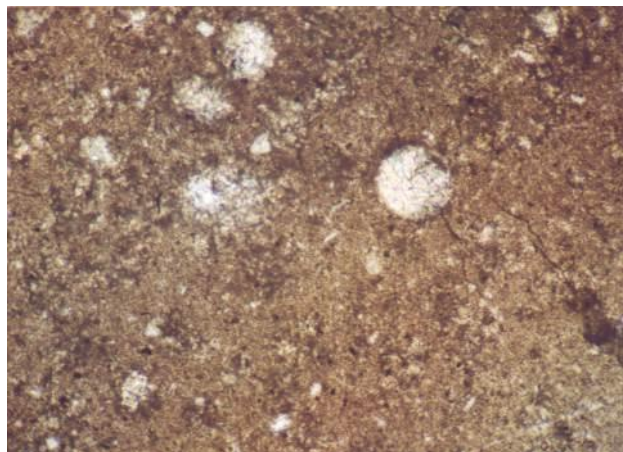


#### 4. RESULTS OF OPTICAL MICROSCOPY ANALYSIS

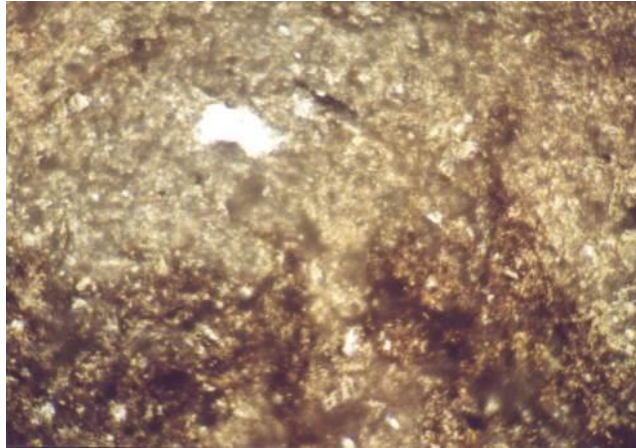
The mineralogical analysis by optical microscopy showed that the deposit rock composition contains both authigenic constituents as argillaceous minerals and additionally fine silica and rarely carbonates, and allogenic constituents as angular and subangular quartz, which might constitute a detrital fraction up to 10 %, and zirconium heavy minerals, tourmaline and pyrite, [7]. The optical microscopy highlighted the influence of diagenesis process on the rocks, by argillaceous mineral recrystallization and argillaceous mineral substitution with sericite and chlorite, Figures 2, 3 and 4.



**Figure 2.** Dolomicrite (calcite recrystallization among dolomite crystals)



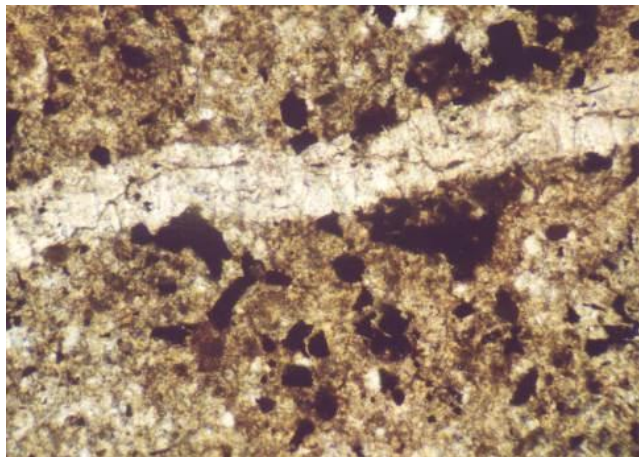
**Figure 3.** Marl (calcite sparitic crystals as rounded formations, marginal attacked by surrounding binding matter)



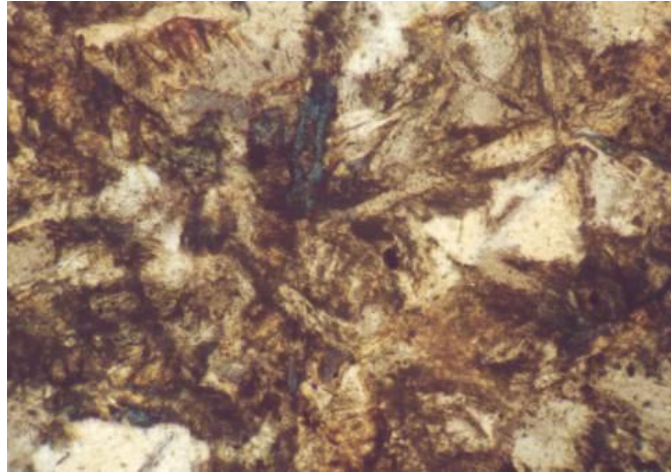
**Figure 4.** Argillaceous marl (argillaceous minerals are frequently converted in sericite and chlorite)

The shales include various types of hard rocks. It should be noticed that, in time, the shales go into the soaking process under the atmospheric factors influence and evidence a ruggedness surface, making difficult to detect the hard bands inside the studied clay deposits.

The optical microscopy analysis on microsections of the core sample, collected from the drilling of detail, showed the hard rock bands inside of argillaceous rock deposit, represented by sandstone, limestone of chemical precipitation, dolomitic limestone or marly limestone or blackband limestone and lime breccia, are all of them characterized by fissure and white spar' eyes, Figures 5 and 6.

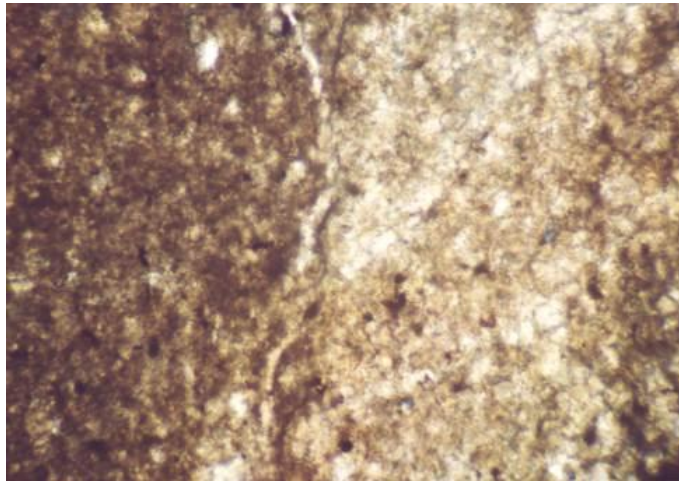


**Figure 5.** Calcilutite (clay bands alternating with carbonate bands and calcite-filled cracks)



**Figure 6.** Feldspathic quartz sandstone (hard rock interbedded into the clay deposit; detrital elements are captured in the basal mass, as: quartz, feldspar, mica)

Rocks with basal mass represented by clay bands alternating with carbonate bands were identified. In this basal mass angular and subangular quartz grains and fine feldspar and mica crystals were locked, Figure 7.



**Figure 7.** Sandstone (hard rock interbedded inside argillaceous deposits; rock matrix is consisted of chlorite, argillaceous and ferruginous minerals)

## 5. CONCLUSIONS

Mineralogical characterization of a clay deposit, as raw material for cement industry, using optical microscopy techniques, identified the mineralogical and petrographic composition. The results indicate authigenic constituents, but also allogenic constituents represented by angular and subangular quartzous that might be a detrital fraction up to 10 %, and heavy minerals of zirconium, turmaline, pyrite.

The optical microscopy analysis highlighted the influence of diagenesis process on the rocks, by agrillaceous mineral recrystallization and agrillaceous mineral substitution. The identified types of rock with high and medium hardness were dolomicrite, calcilulite, sandstone, feldspathic quartz sandstone.

The analysis by optical microscopy has significant importance in diagnosing the petrographic types of the clay deposits and thus to establish their influence on technological behavior of raw materials mixtures in the cement industry.

## REFERENCES

- [1] Davidson M.W., Abramowitz M., 2002, “*Optical Microscopy*“, in Encyclopedia of Imaging Science and Technology, Published by John Willey&Sons, Inc.
- [2] Mc Namara G., Difilippantonio, M. J., Ried T., 2005, “*Microscopy and Image Analysis*”, in Current Protocols in Human Genetics, Cytogenetics, Supplement 46, August 2005, Published by John Willey&Sons, Inc.
- [3] Mutihac V., Stratulat M.I., Fechet R. M., 2004, *Geologia României*, Editura Didactică și Pedagogică R.A., (211-216).
- [4] Anastasiu N., 1988, *Petrologie sedimentară*, Editura Tehnică București, 1988.
- [5] Reading H.G., 1996, *Sedimentary Environments* Blackwell Science, (pp. 395 – 454).
- [6] Posamentier H.W., Summerhayes C.P., Haq B.U., Allen G.P., 1993, *Sequence stratigraphy and facies associations*, Int. Assoc. Sedimentol. Spec. Publ. 18.
- [7] Studies and researches performed at CEPROCIM S.A.

Scientific Reviewer:  
Prof. PhD. Eng. Mircea GEORGESCU

## TYPES OF HARD ROCKS IN THE RAW MATERIAL DEPOSITS FOR THE CEMENT INDUSTRY

ROXANA MAGDALENA FECHET <sup>1</sup>

ADRIANA MOANȚĂ <sup>1</sup>

ȘTEFANIA ELENA DEÁK <sup>1</sup>

IONELA PETRE <sup>1</sup>

**Abstract:** *This paper presents the research results of mineralogical, petrographic, chemical, and mechanical investigations as well, carried out on samples from a clay deposit, as raw material for cement industry. These rocks come from the Barremian–Aptian deposits grown in the Bejan strata facies and consist of black clay slate with banded sandstone rocks, spherical dolomitic and sideritic limestone concretions and basalt, limestone, lava and basalt pyroclastic olistholites [1]. Some of them cannot be used to manufacture cement; they are currently stored in the waste dump within the open pit perimeter.*

**Keywords:** *hard rock, open pit, clay deposit, cement industry*

### 1. INTRODUCTION

Short time after opening the clay deposit, for cement industry, the non-uniform character of the Barremian–Aptian argillaceous deposits making the object of the operation became obvious. This non-uniform character is given mostly by a chaotic dispersion of blocks, inside of the rock mass deposit, having mineralogical, chemical and petrographic composition and also physical and mechanical characteristics radically different from the clays used in cement manufacture. Some rock blocks are angular and slightly rounded, others, completely spherical or ellipsoidal, with sizes between a few cubic centimetres to a few cubic metres, but they have, as a common feature, a considerable hardness. So, in the course of time they have been called *hard rocks*, as a sui generis term. In time, the real geological conditions have imposed adapting of the quarrying flow by introducing operations for crushing and removing of hard rocks, as sterile material, in the waste dumps. In the central area of the open pit, as a result of clay quarrying on upper benches, a basalt block of large size has been uncovered, around which mining pillars have been left in place on every operation bench. The basalt block is irregular in shape and reaches over 25 m high on a bench platform. On the other hand, on the eruptive block berms, other hard rocks have been

---

<sup>1</sup> *PhD, Senior Researcher, CEPROCIM S.A.*

stored, especially representing the eruptive fragments loosened from the central block, coarse and fine sandstone in large slabs, and clay rocks having undergone metamorphosis up to changing into sericitic-chloritic slate improper for cement manufacture because of the high MgO content.

The geological conditions make it obvious that the Barremian–Aptian clay deposits will encounter hard rock's even further and subsequently the sterile material amount of the open pit will increase with the quarrying operation progress. In this context, the sterile material recovery is becoming an economical and ecological requirement, in order to decrease the burden on the environment by reducing both the volume of stored sterile material and the level of pollution impact. By introducing the sterile material into the economic chain, as an alternative raw material, may lead to gain profits and decrease the production costs of the open pit activities. To achieve the settled goal, the assessment of some data regarding the sterile rock types, as result of the quarrying operations, and their mineralogical, petrographic, chemical and physical characteristics are required, in the first stage, [1, 3].

## **2. METHODOLOGY**

Based on mineralogical, petrographics, chemical and mechanical analysis of the sterile rocks sampled from the quarry waste dump, a preliminary assessment of the clay deposit components was achieved. A large variety of lithological types was highlighted, consisting in the following categories: sedimentary rocks (macroclastic rocks, clay-microclastic rocks, chemical precipitation rocks etc.), eruptive rocks and metamorphic rocks.

The main hard rock types encountered in the clay deposit, in a decreasing order of the frequency, are: quartzous sandstone rocks and quartzous-feldspathic sandstone rocks, clay-microclastic rocks, breccia, and polymictic conglomerates, breccia and calcareous microconglomerates, detritogenous limestone rocks, chemical precipitation rocks [3].

The mineralogical, petrographics, chemical and mechanical analysis of the sterile rocks sampled from the quarry waste dump where performed in laboratory by usual techniques.

## **3. STERILE HARD ROCK CHARACTERISTICS**

### **3.1 Quartzous sandstones and quartzous-feldspathic sandstones**

These are abundantly in the sterile dump. They occur in the form of angular blocks sometimes slightly rounded and have the surface covered with black compact hard argillite with glossy faces and deep furrows; sometimes these argillites coating the blocks advance through cracks and fissures into the sandy mass. Sandstone blocks with a low profile of flag, as if are broken from a

2 ÷ 3 m thick layer, occur less often. The blocks have large sizes, of 1 ÷ 2 m<sup>2</sup> up to 4 ÷ 5 m<sup>2</sup> and even larger.

The broken fragments feature sharp edges and corners; often the breaking takes place after calcite coated fracture planes. Macroscopically, the sandstones appear as microcrystalline rocks with granulation from very fine to coarse, very hard, glassy in fracture in the case of quartzous varieties, and coloured from light grey to dark, blackish grey. They show frequent fissures and microfissures filled with white calcite or quartz, both of hydrothermal origin. The blocks disposed of and left in the sterile dump for long show no alteration phenomena, and maintain their compactness and hardness.

### 3.1.1 Mineralogical characteristics

The sandstones mineralogical composition is proper to the rocks with both allogenic constituents represented by quartz, feldspar, mica (Table 1), and authigenic components represented by iron hydroxides, carbonates, heavy minerals, and lithic fragments (Table 2).

**Table 1.** Mineralogical characteristics of sandstones (allogenic constituents)

<b>Allogenic constituent</b>	<b>Mineralogical characteristics</b>
Detrital quartz	It is the main allogenic component and is represented by angular up to sub-rounded grains with sizes from 0.1 mm to 0.6 mm. The quartz proportion varies in the analysed types and exceeds 55 % in the case of quartzous sandstone and decreasing to 30 ÷ 35 % in the case of quartzous-feldspathic varieties
Feldspar	It is present in the varieties of quartzous-feldspathic sandstones in a ratio of up to 20 ÷ 25 %, with angular up to sub-rounded forms; they are represented by acid plagioclastic feldspar rocks (albite-oligoclase) and may occur unaltered, in angular twinned crystals, or may occur altered, sericitised. More seldom occur microcline, which normally gets transformed into clayey minerals
Mica	It is represented by biotite, chlorite, sericite, and muscovite. Sometimes, biotite and muscovite crystals are well developed, with sizes of 0.05 ÷ 1.0 mm. Biotite is often chloritised and afterwards made clayey

The quartzous sandstones show diagenetic transformation represented by biotite's chloritisation and then chlorite's passing into iron hydroxides. Also, clayey minerals appear by altering of chlorite or of certain potassic feldspar. In rocks with carbonate cement, quartz grains are sometimes corroded.

The diagenesis process is also reflected by rare sutural contacts within quartz lithoclasts [3].

**Table 2.** Mineralogical characteristics of sandstones (authogenic constituents)

<b>Authigenic Constituent</b>	<b>Mineralogical characteristics</b>
Film iron hydroxides	They are disposed on fissural and bedding planes, as well as hydrothermal calcite and quartz filling fissures and microfissures in the rock mass. Some of these rocks feature matrices consisting especially of micaceous minerals, crushed quartz and clayey minerals formed by alteration of micaceous minerals. In the matrix structure, iron hydroxides may be noticed, with their presence due to the conversion of biotite into chlorite or the alteration of some iron minerals encountered sporadically in sandstone
Carbonate cement	Some analysed samples feature pore carbonate cement occurring only secondary, or siliceous cement to which mica comes in addition. Siliceous sandstone rocks show siliceous cement with worthy-of-notice fissures filled with hydrothermal quartz (crystals of 0.1 ÷ 3.2 mm)
Lithic fragments	They are present in low amounts, from 2 ÷ 5% to 10 ÷ 15%. Lithoclasts come from various origins: mostly from limestone, dolomite, andesite, and basaltic andesite, and sometimes from quartzite
Heavy minerals	They are represented especially by schorl and zircon and occur accidentally

### 3.1.2 Chemical characteristics

Table 3 presents the chemical structure of the sandstone samples collected from the clay deposit.

**Table 3.** Chemical composition of sandstones

<b>Sample</b>	<b>L.O.I.</b>	<b>SiO<sub>2</sub></b>	<b>Al<sub>2</sub>O<sub>3</sub></b>	<b>Fe<sub>2</sub>O<sub>3</sub></b>	<b>CaO</b>	<b>MgO</b>	<b>SO<sub>3</sub></b>	<b>Na<sub>2</sub>O</b>	<b>K<sub>2</sub>O</b>
G1	2.27	78.97	9.91	3.06	0.86	1.01	0.12	2.06	0.99
G2	5.14	76.33	6.78	2.85	6.18	0.39	0.15	1.57	0.74

The chemical composition of the analyzed samples is typical for quartzous and quartzous-feldspathic sandstones, [3].

### 3.1.3 Mechanical characteristics

Table 4 presents the compressive strength values for sandstone cubic test samples collected from the clay deposit, [3].



**Table 4.** Compressive strength of sandstones

Sample	Cube sizes, mm			Compressive strength, MPa
	L1	L2	L3	
G1	50.10	50.70	50.20	95.70
G2	50.60	50.30	51.60	87.80
G3	50.00	50.00	50.00	40.77

The results of determination place sandstones into the medium to high strength rock category. However, some values pertaining to the low-strength rocks have also been registered because of the failure cracks in the samples (G3 sample), [3].

### 3.2 Clayey-microclastic rocks

Clayey-microclastic rocks distinguish by the association in varying proportions of the clayey material and detrital grains whose size vary from pelitic to psephitic, with a predomination of aleuritic fraction. They are represented by aleuro-clayey slate with transition towards aleuro-sandy or psammo-aleuro-pelitic slate. The clayey-microclastic rocks from the clay deposit are dark grey-blackish, or whitish-grey, massive, compact, slightly rounded blocks coated superficially with black hard argillite rocks penetrating sometimes fissures and fissural planes. Frequently, the blocks show fissures and microfissures and sometimes eyelets filled with white calcite or semitransparent quartz. Broken fragments show track of a very fine micro-stratification and gofferred, banded textures. Sometimes crushing goes after these old bedding planes on whose surface fine mica spangles can be noticed. The size of the blocks varies from 1 m<sup>2</sup> to 3 ÷ 4 m<sup>2</sup>.

#### 3.2.1 Mineralogical characteristics

The psammitic material is represented by quartz and mica, and subsidiary by feldspar grains and femic minerals, Table 5

**Table 5.** Mineralogical characteristics of clayey–microclastic rocks

Constituent	Mineralogical characteristics
Detrital quartz	Quantitatively, detrital quartz varies between 10 and 40 % in aleuritic rocks and reaches 95 % in psammitic areas
Mica	It may reach up to 60 % and is represented by muscovite and biotite, the latter being sometimes unaltered, other times chloritised and baueritised.
Clayey mass	It is pigmented with an organic colloidal pigment (bitumen associated with hydroillite). It contributes to defining the microstratified primary texture as it is distributed along the bedding direction. On the behalf of hydroillite, glomerular or idiomorphous pyrite individualises itself as a diagenesis outcome

As have already been shown, aleuro-clayey slates feature a distinct microstratification coming from alternating fine clayey-detrital laminae and coarser clayey-detrital-calcitic laminae. Textures vary from banded to slaty-plane, goffered and rippled. These rocks are more or less affected by diagenesis effects. Particularly, it is noticed recrystallisation of clayey material passing into sericite and chlorite, with appearance of hydrothermal calcite on microcracks.

### 3.2.2 Chemical characteristics

Table 6 presents the chemical structure of the clayey–microclastic rock samples collected from the clay deposit.

**Table 6.** Chemical composition of clayey–microclastic rocks

<b>Sample</b>	<b>L.O.I.</b>	<b>SiO<sub>2</sub></b>	<b>Al<sub>2</sub>O<sub>3</sub></b>	<b>Fe<sub>2</sub>O<sub>3</sub></b>	<b>CaO</b>	<b>MgO</b>	<b>SO<sub>3</sub></b>	<b>Na<sub>2</sub>O</b>	<b>K<sub>2</sub>O</b>
S1	6.10	57.40	19.20	3.36	4.22	2.99	0.08	5.25	0.27
S2	5.88	50.09	19.21	3.42	3.96	2.92	0.10	5.26	0.24

Typical for these hard rocks is that they feature a similar chemical composition to black clay slate exploited for cement manufacture. In fact, they are black clay slate having undergone diagenesis and intense tectonic movements with the main result being rock compaction and less mineralogical, and thus chemical, composition change, [3].

### 3.3 Polymictic breccia with passing into polymictic conglomerates

Breccia and polymictic conglomerates are massive, compact rocks with splintery fracture. In the deposit they are less frequent than sandstone rocks. In the sterile dump, they occur in the form of blocks of varying size and coated in compact argillite; as with the sandstone, characteristic are millimetre- and centimetre-sized fissures penetrating them and being filled with calcite or white quartz. Sometimes, black hard clay can be seen on the deep cracks across them. Conglomerate rocks have a mechanical structure and psephitic texture and usually are grey and greenish grey in colour, sometimes spotted brownish

From mineralogical point of view, the polymictic breccias include both allogenic and authogenic constituents. Allogenic constituents consist of magmatic lithoclasts (andesite, basalt) sized from 1 to 10 mm and sedimentary rocks (fine clay, aleurite, sandstone, microdolomitospaite) of small size (1 ÷ 2 mm), and sometimes metamorphic rocks (phyllite, sericitic-chloritic slate, quartzous-feldspathic schist resulted from the metamorphosis of black clay shale constituting the Barremian–Aptian mesostasis).

Authigenic components are represented by quartz, chalcedony, carbonates, and iron hydroxides. Polymictic conglomerates feature a detrital matrix consisting of clayey minerals, microscopic quartz fragments or quartz grains, mica, and alteration products of these minerals (sericite and chlorite). In certain analysed samples, effects of hydrothermal solution circulation are emphasised by the presence of carbonate, phlogopite, and hydrothermal quartz, of biotite and iron hydroxides occurring on fissural planes, [3].

### 3.4 Breccia and calcareous microconglomerates

Breccia and calcareous microconglomerates are rocks with psephitic texture and chemical structure, sometimes easily friable, porous at surface, grey, greenish, or yellowish in colour. In the deposit, these rocks occur in the form of slightly rounded, angular blocks of varying size. During the quarry operation they are frequently broken down and found in the sterile dump as irregular fragments.

#### 3.4.1 Mineralogical characteristics

For this type of rocks characteristic are carbonate lithoclasts, some so much transformed that it is difficult to establish their provenance and previous constitution. Breccia rocks are formed from angular, up to sub-rounded, lithoclasts of recrystallised limestone and carbonated lithoclasts, probably of Ca, Mg, Fe, and Mn, sometimes chloritised. Lithoclast sizes vary from a few millimetres to a few centimetres. Lithic fragments also have angular shape up to sub-rounded and varying sizes. The binding material of these breccia rocks is usually of carbonate kind. Diagenesis transformations are represented by massive recrystallisation in the carbonate lithoclast mass.

In some samples, chlorite crystals have been noticed, with certain hydrothermal character indicating postdepositional circulation of iron-rich solutions, [3].

#### 3.4.2 Chemical characteristics

Table 7 presents the chemical structure of the breccia samples collected from the clay deposit.

**Table 7.** Chemical composition of breccia

Sample	L.O.I.	SiO <sub>2</sub>	Al <sub>2</sub> O <sub>3</sub>	Fe <sub>2</sub> O <sub>3</sub>	CaO	MgO	SO <sub>3</sub>	Na <sub>2</sub> O	K <sub>2</sub> O
B1	31.39	19.23	3.73	6.60	23.24	14.70	0.08	0.21	0.27

### 3.4.3 Mechanical characteristics

Table 8 presents the compressive strength values for a breccia cubic test sample collected from the clay deposit, [3].

**Table 8.** Compressive strength of breccia

Sample	Cube sizes, mm			Compressive strength
	L1	L2	L3	MPa
B1	50.00	50.50	50.00	52.48

The result of determination shows a low-strength rock, due to the advanced degree of failure cracks in the tested samples.

### 3.5 Chemical precipitation rocks

The chemical precipitation rock category includes rocks having the shape of spheroid or ellipsoid concretions of varying size, from a few millimetres to circa 1 sq. m or even larger, very similar in aspect to sphaerosideritic concretions in the Cretaceous of Eastern Carpathians. Chemical precipitation rocks are compact rocks of massive microcrystalline texture and chemical precipitation structure, very fine, with conchoidal, slightly splintery, fracture; they give easily effervescence with HCl. Often these rocks feature fine microcracks filled with calcite or quartz. The surface of concretions is covered with black, furrowed, hard argillite [3].

#### 3.5.1 Mineralogical characteristics

Authigenic constituents are represented by carbonates, dolomite, calcite, and/or siderite, Table 9.

**Table 9.** Mineralogical characteristics of the chemical precipitation rocks

Authigenic constituent	Mineralogical characteristics
Dolomite	In dolomitic varieties dolomite can make up to 85–90% of the mass of the rock and occurs in the form of small crystals of 0.01 ÷ 0.06 mm.
Calcite	Calcite occurs much less (up to 10% of the mass of the rock) in the form of xenomorphic crystals of 0.2 ÷ 0.08 mm

Sporadically, an opaque mineral occurs in the structure of the chemical precipitation rocks. Sometimes, the rock is impregnated with iron oxides. On the microcracks, hydrothermal calcite or quartz can be encountered.

Diagenetic transformations of dolomite crystals emphasise their slight rounding off and very slight dedolomitisation and recrystallisation into sparite and microsparite. According to their mineralogical composition, these rocks are dolomitosparite with varying iron content, [3].

### 3.4.2 Chemical characteristics

Table 10 presents the chemical structure of the sideritic limestone sample collected from spherical concretions occurring in Barremian clays.

**Table 10.** Chemical composition of sideritic limestone

Sample	L.O.I.	SiO <sub>2</sub>	Al <sub>2</sub> O <sub>3</sub>	Fe <sub>2</sub> O <sub>3</sub>	CaO	MgO	SO <sub>3</sub>	Na <sub>2</sub> O	K <sub>2</sub> O
C	13.21	33.43	9.08	20.38	11.55	2.91	0.37	0.38	0.82

### 3.5.3 Mechanical characteristics

Table 11 presents the compressive strength of a sideritic limestone samples collected from the clay deposit, [3].

**Table 11.** Compressive strength of sideritic limestone

Sample	Cube sizes, mm			Compressive strength MPa
	L1	L2	L3	
C	45.60	49.30	48.10	53.4

### 3.6 Detritogenous limestone

Detritogenous limestone rocks are compact cataclastic rocks with the character of detrital limestone rocks consisting of fragments of psephitic or psammitic size (calcarenite) with an only but secondary addition of clastic material. With a low frequency of occurrence in the deposit, these rocks occur usually in the form of very large blocks. In the sterile dump they are encountered as angular blocks of large size, and on the 370 m level platform, at the eastern verge of the deposit, there are a few blocks which have actually not been loosened. These blocks mark the boundary of the sterile dump [3].

## 4. CONCLUSIONS

Quarrying the raw material in the open pit, for the cement industry, has a long time impact on the environment by land occupancy due to the sterile dumps. The dump material characterisation is very important for both introducing these steriles into the

economic chain, as an alternative raw material, which may lead to sustain other areas of economic activity, and re-introducing the land into natural circuit.

The results of the sterile rocks characterization are:

- Mineralogical, petrographical and chemical investigations and compressive strength determinations on hard rocks from the clay revealed a variety of rocks pertaining both to sedimentary rocks and to eruptive rocks.
- Mineralogical, petrographical and chemical characteristics of these hard rocks vary within large limits as a result of the multitude of the existing rock kinds. Compressive strength determinations promote these rocks into the medium strength category, but also low compressive strength values may be noticed as a result of either the high degree of failure cracks or the high degree of alteration of the rocks.

In order to assess the possibilities to use these rocks in other economic activity, the relevant knowledge base needs more specific laboratory investigations able to make it possible the reference to standards for various fields of application.

#### **REFERENCES**

- [1] Mutihac V., Stratulat M. I., Fechet R. M., “Geologia României”, Editura Didactică și Pedagogică, 2004
- [2] Opreș S., “Manualul inginerului din industria cimentului”, Editura Tehnică, 1994
- [3] Studies and researches performed at CEPROCIM S.A.

Scientific Reviewer:  
Prof. PhD. Eng. Mircea GEORGESCU

## CLOSING SOLUTIONS APPLIED TO MINES IN JIU VALLEY

FLORIN RĂDOI<sup>1</sup>

**Abstract:** *The exploitation of useful mineral resources in the Jiu Valley is based on specific underground extraction processes. In fact, these involve the connection of several interdependent conceptual and operational elements. These elements are of technical nature, related to extraction, transport, ventilation, equipment, machinery and installations, engineered technological lines and other infrastructure subsystems. In Jiu Valley the mining activity restructuring program began in 1991, addressing the whole complexity of technical, technological, economic and managerial issues. Decisions on the conservation / closure of certain objectives are taken after analysing and completing the feasibility studies on each operating mining unit, which will be accompanied by reconversion programs and projects. The paper analyses, based on actual cases, the closure of each type of mine working connected with the surface.*

**Keywords:** *mining, ventilation, dams, filling operation*

### 1. INTRODUCTION

The causes leading to closure of mines [3] may be as follows:

- mineral resources are depleted;
- the cost of exploitation exceeds certain limits, either because of the deterioration of geological conditions or because of obsolete technologies or excess competition;
- the demand for raw materials decreases so the exploitation has no reason, as long as there is no outlet, irrespective of the economic performance of the unit that extracts the useful mineral substance;
- mining perimeters affected by fire or fire phenomena.

In conjunction with criteria presented, the impact of mining activities on the environment plays a decisive role in the decision to suspend or continue the exploitation activity.

Closure of mines may be:

- total temporary – cessation of activity for a period of maximum 3 months.
- During this period, projects to revitalize the activity are being laid down;

---

<sup>1</sup> *PhD. Eng., INCD INSEMEX Petroșani, Romania*

- partial temporary - cessation of activity for a period of maximum 3 months in some sectors of the exploitation;
- conservation of the exploitation - cessation of the mining activity for more than 3 months, allowing for subsequent revitalization of the activity based on a technical conservation project;
- definitive partial closure - cessation of activity in some mine sectors accompanied by their decommissioning and environmental rehabilitation;
- total and final closure - cessation of mining activity with decommissioning of the exploitation and environmental rehabilitation.

Usually, the decision to close a mine requires the analysis of multiple factors that influence its effectiveness and that can be grouped as follows:

- The class of economic factors, including those elements on the basis of which the closure of a mine leads to improvement of the trader's economic situation, either by increasing the labour productivity of remaining objectives or by reducing the recorded losses;
- The class of natural and constructive factors, referring to the degree of mineral reserve provision, opened and prepared reserves, lengths of transportation, hydrogeological conditions, geological structure, seismic protection, floods;
- The class of social-political factors, which includes:
  - unemployment rate in the area;
  - standard of living and comfort;
  - alternatives in terms of employment;
  - degree of industrial development;
  - possibilities of financial support offered by the state for potential redundant persons who can't find a job.

## **2. TECHNICAL PRINCIPLES REGARDING CLOSURE OF MINES**

According to Safety and Health at Work Regulations (RSSM) of Petroșani National Coal Company (establishment coordinating the branches at the launch of the closure process), Part VI, article 1, closure of mines or active or abandoned parts of the mine (area or sector) [2] will be performed at the initiative of the exploitation license titular (C.N.H.-S.A.), that will submit an application and a technical documentation to the competent authority, respectively the National Agency for Mineral Resources Bucharest (A.N.R.M.), accompanied by the "Activity Termination Plan" (P.I.A.). This technical documentation is prepared by the mine branch in collaboration with a design-research institute, selected according to in force legislation.

The technical documentation, having annexed the necessary approvals and agreements from local and regional stakeholders interested in reducing the environmental impact and social impact on the community in the area, is endorsed by C.T.E.-C.N.H.-S.A. and is submitted to the Ministry of Economy, Commerce and Business Environment - General Directorate of Mineral Resources (M.E.C.M.A.-D.G.R.M.) in C.T.E for further analysis and approval.



The mining activity ceases by decision of A.N.R.M. (representing the competent authority in the field) and M.E.C.M.A., approved by Government Decision, published in Official Gazette (for partial or total financing from the state budget). The "Activity Termination Plan" (P.I.A.) will provide security and health measures for each phase in order to avoid any event, both within the mine as well as within neighbouring mines, as the case may be.

Depending on local conditions of mines, these specific requirements may be completed according to in force legislation.

For activities of closure, dismantling, recovery and technical equipment transportation, work permits will be drawn up regarding safety and health of workers, approved by the head of the branch performing these activities.

The "Activity Termination Plan" (P.I.A.) will include the following:

- the motivation to stop the activity, based on a technical-economic analysis of the current situation;
- the technical decommissioning or conservation program, which will include the post-closure environmental monitoring program. It will be approved in advance by M.E.C.M.A.-D.G.R.M.;
- the social protection program for staff through redistribution and / or occupational retraining, financial compensations and / or regional development measures for creating new workplaces, drafted according to law, after consultation with the affected community groups, approved by the competent authority in the field of social protection, approved in advance by the competent ministry (M.E.C.M.A.);
- water management permit and environmental permit for closure;
- land decommissioning and clearing procedure.

The technical documentation will include the following elements:

- technical-economic memorandum regarding the situation of the mine to be closed;
- phased closure schedule for underground mining works (coal faces, preparatory works, openings, etc.);
- schedule for closing access ways to surface (adits, runs, upraises, wells, drillings with a diameter larger than 200 mm, etc.);
- the phased project for ventilation;
- the program for decommissioning technical equipment to be recovered and power supply points (stations and power distribution points) in conjunction with the mine closure program;
- phased program for the capitalization or demolition of surface constructions and ecological restoration of affected lands (dumps, ponds, excavation pitches, water courses, diving areas, areas damaged by deposits of materials, wastes, building elements);
- prevention and protection plan phased on closing steps;
- general and detailed topographical plans of underground mining activities, completed to date;

- topographical plan of the area, including diving areas, completed to date.

The general and partial ventilation will be performed in correlation with the mine closure stages based on the annual ventilation project (developed according to the RSSM), quarterly reviewed depending on the changes arose in the circuits following the closure stages. The ventilation project will be approved by the technical management of the coordinating institution and will be supported by the technical management of the branch.

### **3. CLOSURE OF UNDERGROUND AND MINE WORKINGS CONNECTED WITH THE SURFACE**

The closure of the underground mining works (coal faces, first mining and development workings, etc.) will be carried out in a phased manner, backing from the mine field boundary towards the ventilation circuits, found under the general depression of the mine, inclusively towards the surface connection paths, based on a technical closure project that will include:

- the state of mine workings in terms of support, free profile, set-up and traffic and transportation possibilities. Where needed, the mine workings to be re-engineered or those needing the transportation path for the evacuation of recovered technical equipment to be rebuilt shall be specified;
- schedule for the closure of underground mine workings by horizons (elevation marks) and within each horizon;
- access ways (circulation and transport) for each closure stage, indicating routes for evacuation of recoverable machinery;
- mine workings closure technology (backfilling, directed caving in or abandonment as they are). Mechanical installations (devices) used to recover support;
- types of mine closure dams, along with their site location on topographic plans. In areas with possible floods, the dams will be sized to withstand the foreseeable water pressure;
- the flow of accumulated water and the forecast of mine workings flooding over time. The risk of water accumulation for neighbouring mines or an unabandoned part of the mine and measures to prevent their flooding;
- risk perimeter for surface caving-ins and time tracking of the caving area.

The closure of mine workings connected with the surface (adits, runs, upraises, wells, drillings with a diameter larger than 200 mm, etc.) will be carried out based on a technical project that will include:

- closure of mine workings with a less than 30° dip (adits, runs):
  - Approach of mine workings closure:
    - by backfilling for mine workings that have as ceiling, all the way up to the surface, a package of rocks, not thicker than 50 m;
    - by taking of the metal props or leaving the working as it stands, if the working is caved in stable rocks and if the stability of surface terrain is certified by

geotechnical studies; in this situation measures will be taken to avoid the entry of foreign persons into the underground through excavations behind the dams;

- backfilling will be performed with the use of flight conveyers, conveyor belts, front dump cars or by hydraulic transport of a consistent mixture of thermal ash and water, with binder additions, put into operation by means of a kneading -pumping aggregate, the pulp being directed to the place of deposition by pipes or hoses.

○ Approach of mine entrance closure for mine workings connected with the surface

- with safety earth walls, for workings that were closed by backfilling;

- with concrete stoppings having a thickness of minimum 0.5 m, embedded in compact rock throughout the entire perimeter, for workings that were closed by taking of the metal props or leaving the working as it stands.

○ Setting up safety pipes within mine dams: “swan neck” type safety pipes will be installed within dams, for water evacuation.

• closure of mine workings with a dip higher than 30° (adits, raises):

○ Approach of mine workings closure:

- by building a dam, resistant to the backfill pressure, embedded in the walls of the adit or raise, located at an accessible point, where the thickness of rocks in the mine working’s ceiling, all the way up to the surface, measures at least 50 m vertically;

- by backfilling the mine working between the dam and the adit or raise entrance;

- for dips lower than 60°, backfilling will be performed with the use of flight conveyers, conveyor belts, gutters or downstream pipelines or by hydraulic transport of a consistent mixture of thermal ash and water, with binder additions, put into operation by means of a kneading -pumping aggregate, the pulp being directed to the place of deposition through pipes or hoses.

○ Approach of mine entrance closure for mine workings connected with the surface

○ - with at least 0.5m thick safety earth walls embedded in compact rock over the entire mining area;

- or with a reinforced concrete plate, resistant to a pressure of 32kN / m<sup>2</sup>;

○ Setting-up gas control pipes and fireproof pipes within dams and fitting the concrete plate with window, for monitoring the level of backfill and the fireproof gas drainage pipe, if necessary. When closing ascendant mine workings, “swan neck” type safety pipes will be installed within dams and pipes, for water evacuation.

• closure of vertical mine workings (circulation and ventilation shafts, air funnels and boreholes having a diameter larger than 200mm):

○ the required amount of backfill material depending on the pit volume and density of the material used;

○ type of backfill material and its granulation, stating that:

- the maximum grogs size will not exceed 250 mm;

- a material that has no tendency to form vaults, having a grain size of less than 100 mm (gravel, slag, sandstone, concrete or brick pieces) is used on the last section of 50 m to surface;
- if the occurrence of air - methane mixtures is possible, wet and fine grain backfill material is required;
- in the case of water accumulation in the pit, it is necessary to use backfill with a specific gravity of more than 1.3 kg / dm<sup>3</sup>;
  - o forecast of the water flow that accumulates in the pit and from where it flows;
  - o methane emission regime and areas where it may occur (abandoned mine workings, coal tar interceptions and tectonic disturbances);
  - o the necessary preparatory work to be carried out before the pit's backfilling:
    - construction of dams in the workings connected with the surface with the pit or box-hole raises, which are to be backfilled, dimensioned at the pressure created by the backfilling material, in order to prevent the leakage of the material through these workings;
    - if possible as safety is concerned, removal of set-ups in the pit, obstructing the section and preventing free fall of the backfill;
    - setting-up of the pit entrance in order to avoid putting in oversized backfill material;
    - assembling the means of continuous transportation of backfill material towards the point of discharge into the pit;
    - fencing the surface restricted area, within 20 m radius around the well, until the end of the backfilling activity, to prohibit the access of the unauthorized persons; in this respect, warning signs stating prohibited access will also be displayed;
  - o organizing the backfilling activities with reference to:
    - periodic tracking of filling level and material used as backfill, in accordance with the project;
    - tracking the shrinkage of the backfill column and filling it up after completion of the backfilling activities;
    - the method chosen for filling up the voids under the reinforced concrete plate, resulted after shrinkage, with backfill material. When applying the technology, account shall be taken of the relatively small size of the manway and that by gravitational disposition complete filling of voids is not possible;
- o the means for sealing surface connections with the pit (ventilation ways, ducts and cable ways, pipes, etc.);
- o means of pit closure module by using a reinforced concrete plate resistant to a pressure of 32kN / m<sup>2</sup>. Possibilities of using the support from the pit entrance as a prop surface for the closure plate;
- o means of fitting the closure plate with an observation window, for monitoring backfill column levels and the gas drainage pipe, when necessary;
- o means of surface marking the center of the well entrance, in case the closure decision provides for the reinforced concrete plate to be covered with a layer

of soil. The mark shall bear the name, the axis coordinates and the diameter of the well;

- the graphic part (pit section and its set-up, pit height profile, major tectonic strains and disruptions intercepted when digging the pit, shop drawing for the closure plate.

Pit filling operations shall be carried out without intermittences, with no breaks allowed. As far as possible, when performing pit's backfilling the intercepted groundwater shall be taken into account and shall be recovered by a bed of clay of at least 20 m vertically.

Pits must be secured with decommissioning to avoid endangering the surface and population. Pits backfilling can be performed by using the following types of materials:

- shattered hard rock,
- loose ground (gravel, sand),
- sterile, impermeable rock,
- cohesive backfill (e.g. concrete).

Best practices applied to pits found in unstable rocks are full length backfilling, using hydraulic acceleration methods and materials stable in the presence of water, before the uncontrolled flooding of the mine begins.

In accordance with the European standards in force, for pits dug in stable rocks, the following remedial measures can be applied:

- construction of a massive reinforced concrete plate in the pit, in the filling area closest to the surface, followed by gravel or concrete backfilling up to the entrance of the pit;
- building a strong concrete plug embedded in the pit at a depth accessible from the surface, followed by backfilling up to the surface with gravel or concrete;
- total backfilling with or without hydraulic acceleration.

The entrance of the pit backfilled with unconsolidated rock must be covered with a reinforced concrete plate. The concrete plate must be provided with an access window to monitor and apply any refill measures.

Surface access works (slopes and galleries) should be closed shortly after the closure decision has been taken, for reasons of population's safety. Choosing the right closure or remediation technology depends on the following factors:

- location of the gallery in relation to the surface,
- geological and hydrogeological conditions,
- gallery function,
- general state of the gallery in terms of stability and accessibility.

In order to achieve a correct closure of abandoned galleries, the following constructive solutions compatible with best practices can be adopted:

- construction of a dam at the gallery's entrance out of precast concrete or concrete;

- backfilling a minimum 10 m long section, immediately behind the gallery opening (the total length of the backfilled area varies depends on surface stability on the gallery alignment);

- full gallery backfilling;

- closure of the gallery entrance by detonation for caved-in galleries in order to restore the natural environment.

- closing a gallery entrance with a lockable iron gate is only permitted until the closure activities begin.

Mine flooding is an integral part of the mine closure and rehabilitation process. After completion of the preparatory activities (backfilling, stabilization, removal of contaminated machinery, recovery of recyclable metals, etc.), mine water discharge will be reduced and finally stopped. At this stage, the natural intake of underground water will lead to mine filling (uncontrolled flooding).

Flood concepts and strategies need to be adapted to site specificity, but without omitting well-established routine procedures. It is necessary to continually update the concept underlying the flood and adapt it to the results of the monitoring that is being carried out concurrently (flood monitoring).

#### 4. CONCLUSIONS

The decision to begin the process of closing and preserving a mining objective requires the analysis of a complex of factors that interact and influence the efficiency of decision.

Underground and surface openings and uncovering activities may not necessarily require backfilling, especially if they represent an essential part of the conservation patrimony and do not pose a threat to public security. In some cases, it is acceptable to install a fence or barrier of sufficient height, possibly provided with a trench (filled with water, if local conditions allow it).

The anthropic modelling of the relief generated by mining activities does not stop after the extraction activities have been closed. The need for safety and aesthetic sense stimulates research and represents a perpetual challenge for scientists in different fields. Refurbishment of the space occupied by the primary exploitation and resource processing infrastructure is generating new technostructures that appear in the landscape and require constant monitoring until equilibrium of the area is reached.

#### REFERENCES

- [1]. Rădoi F., Current situation of mines in the Jiu Valley, subject to closure process, Paper no.1, University of Petrosani, 2016.
- [2]. Solschi A. G., *Technical program of Paroşeni mine closure*, 2011.
- [3]. \*\*\* Mine law no. 85/2003.

Scientific Reviewer:  
Prof. PhD. Eng. Eugen COZMA

## RECLASSIFICATION OF PRAID SALT MINE BY THE RATE OF GAS EMISSION

EMERIC CHIUZAN <sup>1</sup>  
DORU CIOCLEA <sup>2</sup>  
ADRIAN MATEI <sup>3</sup>  
ION GHERGHE <sup>1</sup>  
CORNELIU BOANTA <sup>1</sup>  
CRISTIAN TOMESCU <sup>4</sup>

**Abstract:** *The purpose of this paper is to determine the rate of methane (explosive gas) and of carbon dioxide (aophysant gas) in the mine workings of Praid salt mine. Currently in Romania there are six salt mines which exploit the salt through underground mine workings: Praid salt mine, Tg. Ocna salt mine, Slanic Prahova salt mine, Ocnele Mari salt mine, Cacica salt mine, and Dej salt mine. Of these six, in three salt mines occurred gas and salt eruptions: Praid salt mine, Slanic Prahova salt mine and Tg. Ocna salt mine. The purpose of the present paper is to establish the methane release (explosive gas) and the carbon dioxide release regime in mine workings from Praid salt mine in order to verify its classification. This verification of the Praid salt mine classification has been carried out during October 2012 and the following elements have been taken into account: Geological and technical-mining conditions of the salt deposit related to Praid mining perimeter; Results of the quantitative and qualitative measurements from the underground mine workings regarding: a) Circulated air flows; b) Measured methane and carbon dioxide concentrations; c) Absolute flows registered; d) Accumulation capacity of gas in the deposit; e) Gas concentrations and pressure in the massif. Existing evidences and documentations regarding the previous gas occurrences and their manner of manifestation; Establishing the way in which the gas is released into the underground atmosphere of the mine workings. Based on the observations and on the carried out measurements, on the analysis of the studied geological and mining elements, the classification proposal has been made for the Praid salt mine from the point of view of gas emissions (methane and carbon dioxide).*

**Keywords:** *salt mine, methane release, carbon dioxide release, gas emission*

---

<sup>1</sup> *PhD. Student scientific researcher INCD - INSEMEX Petroșani*

<sup>2</sup> *PhD. Eng. head of laboratory INCD - INSEMEX Petroșani*

<sup>3</sup> *PhD. Student research assistant INCD - INSEMEX Petroșani*

<sup>4</sup> *PhD. Eng. scientific researcher INCD - INSEMEX Petroșani*

## **1. INTRODUCTION**

The presence of marsh gas in underground atmosphere of Praid salt mine was highlighted both by geological drillings performed for exploring the deposits and by opening, preparation and exploitation workings [1].

Systematic measures carried out in 1976 by INCD - INSEMEX Petrosani, to determine the category that Praid salt mine falls into in terms of the gas emanation, revealed the existence of marsh gas in the holes that were bored in the salt massif for shooting the coal face and the 657 run to open a new horizon, marsh gas concentrations ranging from 4.2 to 5.14% vol. In the holes bored at the contact area between salt and surrounding waste rock measured concentrations of marsh gas went up to 84% vol.

## **2. AN OVERVIEW OF DEPOSIT AND MINING PERIMETER GEOLOGY**

Praid rock salt deposit from the mine is part of the saliferous area on the eastern frame of Transylvania basin at the base of Gurghiu Mountains. The deposit is located in the central part of Sovata - Praid – Corund area and takes the form of a dome flanked by sedimentary or volcanic miopliocene or quaternary formations.

Horizontally the deposit has an approximately circular shape (NE - SW axis and NW-SE axis of 1.2 - 1.4 km). Vertically, based on the structural boreholes performed, it is appreciated that Praid diapir dome of rock salt has a height of 2.6 to 2.8 km, being the deepest and thickest rock salt massif in Romania. The salt diapir is flanked by sedimentary rocks, partially covered by volcanic formations. Its quality, in terms of impurities (found in the form of impregnations including enclaves in size up to several cm, made of clay, marl, sandstone, gypsum, anhydride, but also massive sterile insertions frequently occur) places it behind other deposits in exploitation in the country.

## **3. OPENING, PREPARATION AND EXPLOITATION OF DEPOSITS**

The first underground salt mine dates back to 1762 and is located in the south-west side of Spatele Sarii hill.

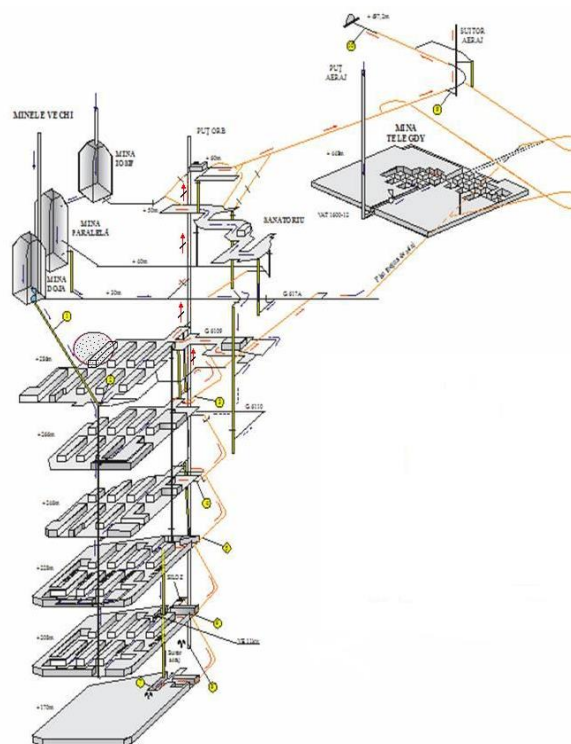
The systematic exploitation of salt began in 1787 when exploitation of Iosif mine began, the Paralela mine (1864), Elisabeta mine (1873) and Gh. Doja mine (1947).

The current mine located under the Gh. Doja mine was opened from the surface by an adit located at elevation +497.2 m, which continues with a run that descends to elevation +474.5 m, respectively +427.0 m. Opening the depth of the deposit was performed by a blind shaft from elevation +427.0 m to elevation +208 m and through the auto run between elevation +474.5 m and elevation +170 m (Fig. 1).

In 1991, the preparation and opening of a new sector began, Telegdy mine, accessible through a side split of the main transportation gallery. Extracting salt from the massif in Telegdy mine is performed by small rooms and rectangular pillars



exploitation method. The rooms have a width of 16 m, height of 8 m and length up to 20 m. The pillars are 14 m wide, 8 m in height, 14 m long and have a thickness of 8 m.



**Figure 1.** Praid salt mine

Currently production activities are carried out in blocks no. 4, 8, 9 and 17. After exhaustion of the reserves at horizon +228 m salt exploitation will continue through the horizon +208 m, respectively horizon 170 m (horizon under way of being opened). Salt exploitation is performed through the small rooms and rectangular pillars exploitation method. The rooms have a width of 20 m, 12 m in height and between 20 and 275 m in length. Pillars are 20 m wide, 12 m high with a length between 95-100 m.

Between the horizons there is safety floor, having a thickness of 8 m. Exploitation of different floors is performed in descending order.

Beside the extraction of salt, an opened all year long asthmatic asylum is located at horizon 50 (elevation 407.0 m).

#### **4. PRAID MINE VENTILATION SYSTEM**

Praid salt mine general ventilation is achieved through an aspirant- forced draught system, the two main ventilation installations being located underground. The

air flow direction is descended from the old mines, Iosif, Paralela and Gh. Doja mines, situated above horizon +339, being under the influence of the depression created by the fan. Fresh air is discharged on the ventilation rising up to horizon +230.0 m and through the network of ventilation galleries, at the level of each horizon. Return air is exhausted to surface through the chamber's pathway, auto transportation runs from each horizon, blind extraction shaft, blind shaft ramp horizon +426.0 m, main auto transportation run, coast gallery.

## **5. MEASUREMENTS PERFORMED IN UNDERGROUND WORKINGS**

To establish the scheme of gas emissions, respectively the classification, depending on the absence or presence of methane and carbon dioxide, quantitative and qualitative measurements were carried out, in the main and secondary return air exhaust currents, in the active, inactive and reserve mine workings [2].

In addition to these measurements, specific measurements were also performed to establish the presence of methane during some technological operations such as:

- Punching blowholes in the salt massif;
- Performing the path at the coal face base;
- Measurement of gas concentrations in the coal face, rooms ceiling and in general exhaust air currents of the horizons and mine.

Measurements in active mine workings were performed also for a preparation work, where partial ventilation was stopped for 24 hours.

Prospecting for marsh gas in the salt massif around mine workings, was performed through advance boreholes in which were inserted gas collecting probes. These were sealed for 24 hours. Also to this purpose were performed measurements in a horizontal bore, performed toward the salt-sterile limit [4].

## **6. MEASUREMENT RESULTS**

The results of the measurements performed in the underground atmosphere and the salt massif highlighted the following:

- Absence of methane in the mine's primary and secondary return air exhaust currents;
- Presence of methane in the salt massif around mine workings having the following concentrations:
  - ▶ 3 ppm in the boreholes performed in the preparatory work front – auto transportation run to horizon +188 m;
  - ▶ 1% vol. in the G2 test drilling, located at horizon +208, in chamber 6400, at more than 24 hours after sealing;

- Presence of carbon dioxide in the atmosphere of mine workings in concentrations up to 0.3% vol. (value measured in the cesspool of the blind pit);
- Lack of gas pressure in advance boreholes performed in the salt massif;
- No blower of methane or other manifestations of gases were shown.

Considering the results of measurements and observations performed by INSEMEX Petrosani in Praid salt mine underground workings during 1985, 1986, 1989, 1994, 1996, 1998, 2001, 2003, 2005, 2007, 2010 and 2012, respectively 2014 we made the suggestion of differentiating Praid underground mine workings into “**mine areas**<sup>5</sup>” and properly classifying them in terms of gas emission as follows:

- absence of methane in technological processes at coal faces, such as: performing advance boreholes and scaling coal faces or after performing shooting activities at coal faces;
- absence of methane in the underground atmosphere if the partial ventilation system is shut for a period of over 24 hours;
- presence of methane in the salt massif and marginal waste rock around underground workings (advance boreholes and pits F-166, inclined F-166, F-166 bis);
- absence of carbon dioxide in the working’s atmosphere and its presence in the salt massif;
- lack of gas pressure in advance boreholes performed in the salt massif;
- no blower of methane or other manifestations of gases were shown.

## 7. CONCLUSIONS AND RECOMMENDATIONS

Considering the results of measurements and observations performed by INSEMEX Petrosani in Praid salt mine underground workings combined with previous occurrences of gases we made the recommendation to keep the classification as “1st Category gassy” considering methane emissions and as “1<sup>st</sup> CATEGORY” considering carbon dioxide emissions [5].

Given the dynamics of methane concentrations in underground workings over the years and the experience gained by NRDI INSEMEX Petrosani in this field, we recommend **changing the classification criteria for salt mines by dividing them into clearly delineated mine areas, intended for opening, preparation and exploitation of the salt massif through underground workings.**

Salt mines, mining areas or underground workings where the presence of methane hasn’t been detected, will be classified as: non gassy.

Salt mines, mining areas or underground workings where the presence of methane has been detected, will be classified as gassy:

---

<sup>5</sup> Note: –clearly defined parts of the salt mine intended for salt extraction, for example: active , inactive, reserve chambers or dead-holes opening or preparatory activities.

- of non gassy conditions, active, inactive and in reserve mine workings found under the depression/pressure created by main ventilation fans;
- and maintaining the classification as "1st Category gassy" for:
  - dead-hole coal faces ventilated through partial ventilation;
  - coal faces where the following activities are performed: cutting path with cutting machinery, drilling holes for blasting, blasting the coal face, loading;
  - chambers where bore holes are performed for analyzing the salt deposit or sterile intercalations and the salt / sterile contact area;
- lack of classification in terms of carbon dioxide emissions since the presence of this gas in the underground atmosphere, hasn't been detected in concentrations greater than 1%.

When opening a new horizon, it will be considered as non gassy only if the analyzing works/drillings haven't revealed the presence of marsh gas and the horizon's classification will be made only after performing the first circuit of the mine ventilation under the general depression of the mine.

#### **REFERENCES**

- [1]. X X X - *Technical report presenting Praid salt mine*;
- [2]. E. Chiuзан – *Assessing the gas emanation state - methane and carbon dioxide - to verify the classification category of Praid salt mine, studies - NRDI INSEMEX 2006-2016*;
- [3]. D. Tulica, I. Toth – *Analysis of gas parameters in the salt massif from Praid salt mine, NRDI INSEMEX study 1986*;
- [4]. *Test procedure for measuring gas emissions in underground workings - NRDI INSEMEX Petrosani*;
- [5]. *Assessment procedure on approval of documentation concerning the classification of mines in terms of gas emanation - NRDI INSEMEX Petrosani*.

Scientific Reviewer:  
Prof. PhD. Eng. Eugen COZMA

## FUNCTIONAL PARAMETERS ANALYSIS OF INDUSTRIAL VENTILATION INSTALLATIONS

ION GHERGHE <sup>1</sup>

**Abstract:** *Industrial ventilation is an extremely complex area that involves deep knowledge of dynamics, three-dimensional heat propagation, complex fluid flow, steady state, operating problems, contaminants inside and outside of industrial premises, etc. Industrial ventilation installations aim at ensuring the conditions of air purity and microclimate corresponding to human activity and the nature of the technological process. These ventilation facilities contribute to maintaining work capacity, removing occupational diseases, increasing labor productivity and the quality of work-related products. These considerations are sufficient to ensure the proper functioning of industrial ventilation facilities. The paper will look at how to check the operating mode for a complex ventilation system.*

**Keywords:** ventilation, parameters, security, environment.

### 1. INTRODUCTION

Ventilation is the mechanical system inside a building that brings “fresh” air from the outside, and eliminates the “contaminated” air from the inside. [2].

Ventilation is used for controlling the exposure to air pollutants, to remove impurities such as smoke, dust and vapors, in order to ensure a healthy and safe working environment.

Ventilation can be done either by natural means, by opening a window, or by mechanical means using fans or blowers. Industrial systems are designed with the purpose of moving a quantity of air to a certain speed, resulting in the removal (or "discharge") of undesired pollutants. While all the ventilation systems follow the same basic principles, each system is specially designed to match the work type and the release rate of all the pollutants to that certain working place [2].

In order to obtain optimal given temperature, pressure and humidity conditions inside the ventilated premises, the air will be subject, in advance, to a complex treatment process which can include warming, cooling, humidification, dehumidification, filtering etc.

---

<sup>1</sup> *PhD. Student Eng., National Institute for Research and Development in Mine Safety and Protection to Explosion – INSEMEX*

## 2. TYPES OF INDUSTRIAL VENTILATION SYSTEMS

Ventilation is considered an “engineer control” with the purpose of eliminating or controlling the pollutants released in the working environments from the inside. It is a preferred method of controlling the employees’ exposure to air pollutants [2].

In accordance to the premises subjected to ventilation, the systems can be classified in general, partial, local and mixt ventilation, such as [1]:

- General ventilation systems, that serves the entire building and consists in displacement of the entire air volume of the occupied area,
- Partial ventilation systems, which applies only to very large halls serving just a certain sector of it,
- Local ventilation systems are applied directly to toxic emissions source
- Mixt ventilation systems can be accomplished through simultaneous application of local, partial and general ventilation inside a building.

In accordance to the pressure regime that the systems tend to create inside, the systems can be classified in:

- Fresh air intake systems
- Systems for external fresh air inlet and upset into the ventilated area
- Air inlet systems of vicious air, which brings out the contaminated air from a building and evacuates it on the outside.

If we inlet some air from the exterior in a building, the overpressure created can be a vitiation source for the surrounding areas. In this case will be applied, in general, the equilibrium systems principle, as in the airflow of the air exhaust from a a room must be controlled with an equal fresh airflow inlet by a separate installation.

- Comfort systems have the purpose of achieving comfortable conditions for the people in the attended room.
- Ventilation systems with hygiene role, used in rooms filled with noxious emissions, tend to accomplish, outside the comfort zone, air purity conditions, through evacuating noxious substances and replacing the foul air with fresh air brought from the outside.
- Ventilation systems with technological role, serve the industrial processes or machines such as pneumatic conveying installations, combustion air supplying installations for boilers, ovens etc.
- Ventilation systems with protection role, have the purpose of achieving some environment conditions to combat fire or explosion risk created by continuous gases, vapors or dust release inside of a certain production chambers or materials storage.

Failure ventilation systems for rooms susceptible to instantaneous accumulation of toxic, flammable or explosive substances, caused by equipment malfunction / breakdown.

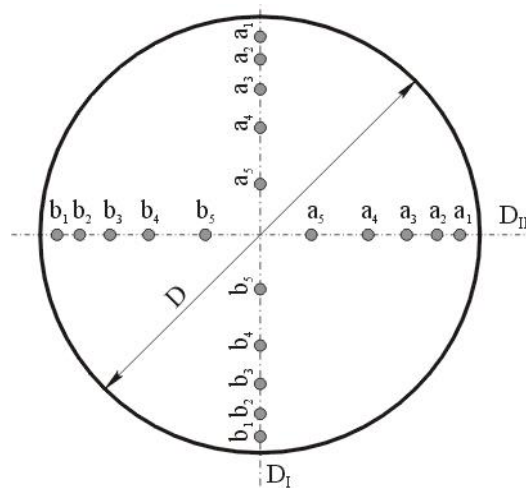
### 3. THE MEASUREMENT METHOD FOR AN INDUSTRIAL VENTILATION INSTALLATION

For measuring the functional parameters (air flow and pressure) as related to a ventilation installation made of circular tubes columns, simple or branched, to determine aerodynamics factors ( $R_0$  și  $K_0$ ), we proceed as it follows:

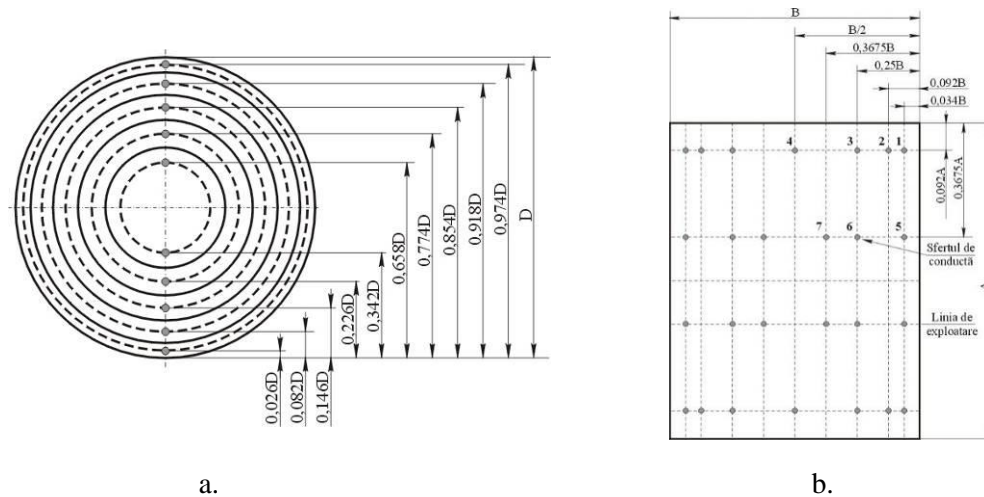
The stream of air speed in the tube column is measured in a point located to a distance of  $5 \times D_m$  (exhaust ventilation),  $10 \times D_m$  (suppressed ventilation) to position of the fan.

When using rectangular ducts, the distances calculated by inserting the Pitot-Prandtl tube from the inner edge of the pipe to the pressure points are shown in figure no. 2b. Determination of air speed is made by direct method (is being directly measured the speed of air through Pitot-Prandtl tube, which is connected to an electronic device through flexible hoses ( $D$ - column diameter) [4]. The measuring of dynamic pressure ( $h_d$ ) is being made on surfaces of equal pressures with equal velocity fields, perpendicular on airflow direction and it's executed on two perpendicular diameters  $D_1$  and  $D_2$  (figure 1) [1], [2], [3], [8].

The measured distances of introduction of Pitot-Prandtl tube from the interior edge of the tube until the pressure points given the conditions in which the indirect method is applied, are indicated in figure 2 a,b.



**Figure 1.** Measuring point of dynamic pressure on two diameters



**Figure 2.** Insertion distances of Pitot-Prandtl tube  
*a. Circular ducts b. Rectangular ducts*

Static depression ( $h_{st}$ ) is measured through connecting the additional pipe to measuring device, and the Pitot-Prandtl tube is being introduced in the tubes column at a depth of  $1/3 D$ .

Air speed is being measured at the end of the air suction or pressure in and from the tubes column, using electronic anemometers which determines the status parameters of the air. It's being measured the length of the tubes column which is located between two measuring points or between the fan and the end of the suction or compression column of the air.

For rectangular ducts, the velocity shall be assessed separately on a quarter of the pipe by the average of 24 values obtained by considering twice the values in points 1, 2 and 3, three times the values in points 3, 4, 5 and 6 and six times the values in point 7 according to the relationship.

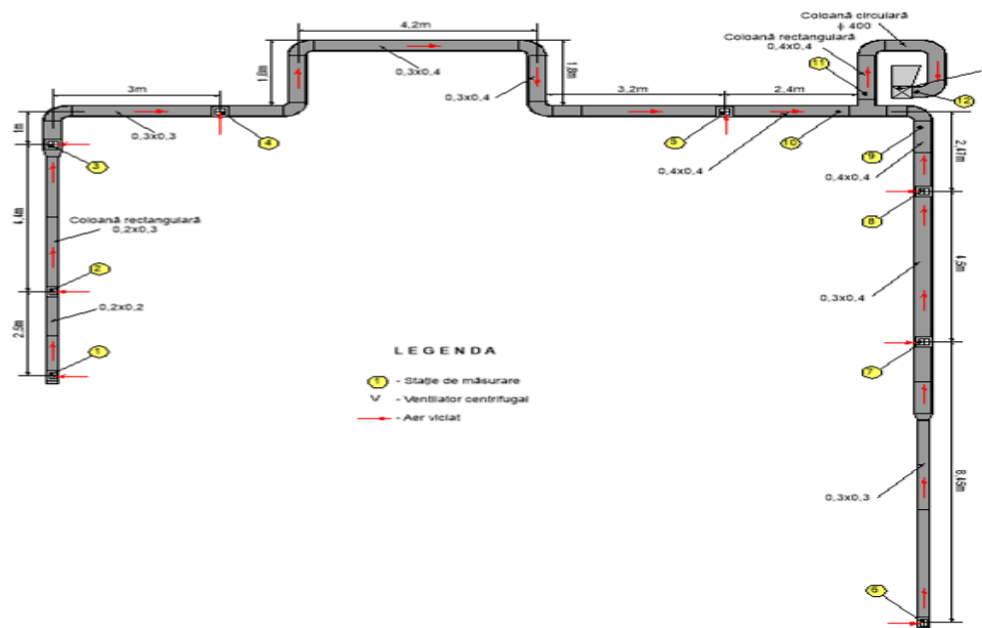
$$V_{1/4} = \frac{1}{24} [2 (V_1 + V_2 + V_3) + 3 (V_3 + V_4 + V_5 + V_6) + 6 \cdot V_7]$$

The average speed across the section of the pipe is obtained by performing the arithmetic average of the four average speeds per quarter of the pipe or direct speed measurement using the pitot tube connected to an electronic device.



#### 4. MEASUREMENT RESULTS

In figure no. 3, there is shown a branch industrial ventilation installation consisting of a column of rectangular metal tubes served by a centrifugal fan located outside the room.



**Figure 1.** Installation of branched ventilation

The centrifugal blower is CMP - 1845 - 6T type and has the following rated parameters:

- debit: 9.000 m<sup>3</sup>/h (150 m<sup>3</sup>/min);
- depression: 75 water column (736 Pa);
- speed: 930 rot/min.;
- rated power: 2,2 kW.

The total length of the ventilation column is 41 m, of which the nr.1 branch has 25,5 m and branch nr. 2 has 15,45 m.

On the two branches there are eight air intake openings from the inside of the magazine, of which 4 suction nozzles are on the branch no. 1 and four suction nozzles on the branch no. 2.

For sealing of the ventilation column consisting of variable rectangular metal tubes, silicone seals are used and the connection of the tubes with flanges and screws. The connection of the rectangular column with the fan is made with a 300 mm diameter circular rigid column.

In the measuring effectuated in the representative points specific to ventilation installations considered, the main target was obtaining the following parameters:

- The static depression (pressure) in ventilation column and in the measuring points of air speed currents.
- Average velocity of air in the column, in the measuring stations of air flow;
- Ventilator air flow, at suction slot ventilation, in branched points of the column or in static null depression points;
- Air temperature inside the ventilation column and in the airflow measuring stations;
- Dimensions and length of the ventilation column;
- The distance between ventilators and the length of the column correspondent to each ventilator and/or branch.

Results of the measurements are presented in table no.1.

**Table 1.** Measurements results made in place

Location	Measuring station	Static Depression (pressure) $h_{ST}$ (Pa)	Temperature $t$ ( $^{\circ}$ C)	Pipeline section ( $m^2$ )	Air speed $V$ (m/s)	Measured Air flow $Q_m$		Corrected Air flow $Q_c$	
						$m^3/h$	$m^3/s$	$m^3/h$	$m^3/s$
0	1	2	3	4	5	6	7	8	9
Ventilation system for chemicals, catalysts and oils	1	98,1	27,0	0,0352	2,98	377,64	0,1049	357,62	0,099
	2	104,0	27,0	0,06	4,59	991,44	0,2754	938,89	0,2608
	3	138,3	27,0	0,09	5,71	1850,04	0,5139	1751,98	0,4866
	4	162,8	27,0	0,09	8,6	2786,4	0,774	2638,72	0,7329
	5	247,2	27,0	0,12	10,36	4475,52	1,2432	4238,31	1,1773
	6	196,2	27,0	0,0391	1,41	198,0	0,055	187,5	0,052
	7	202,1	27,0	0,09	1,91	618,84	0,1719	586,04	0,1627
	8	208,0	27,0	0,12	2,92	1260,0	0,35	1193,22	0,3314
	9	225,6	27,0	0,16	2,25	1296,0	0,36	1227,31	0,3409
	10	277,6	27,0	0,16	7,95	4579,2	1,272	4336,5	1,2045
	11	451,3	27,0	0,16	10,25	5904	1,64	5591,08	1,553
	12	500,3	27,0	0,07	23,7	5972,4	1,659	5655,86	1,571

## 5. WAYS OF ACCOMPLISHING VENTILATION

To determine aerodynamics parameters specific to ventilation columns,  $R_0$  – uniform aerodynamic resistance and  $K_0$  – uniform rate of air loss through leaks, has been used the dates presented in table no1.

These parameters have a practical importance because they mostly determine the efficiency of the ventilation installations, made through tube columns.

After performing calculations, the unit aerodynamic drag corresponding to branch no. 1 (point 1-2-3-4-5-9) has recorded values within the limits  $8,4109 \div 88,0457 \text{ N s}^2/\text{m}^8/\text{m}$ , with an average value de  $37,2382 \text{ N s}^2/\text{m}^8/\text{m}$  – Table no. 2.

The unitary aerodynamic strength of the branch no. 2 (point 6-7-8-10) recorded values within the limits  $24.7459 \div 75.3222 \text{ N s}^2/\text{m}^8/\text{m}$ , with an average value of  $54.2414 \text{ N s}^2/\text{m}^8/\text{m}$  - Table no. 2

It follows that the aerodynamic strength of the column for branch no. 1 is:

- $R_1 = 37,2382 \text{ N s}^2/\text{m}^8/\text{m} \times 25,5 \text{ m} = 949,5741 \text{ N s}^2/\text{m}^8$
- $R_2 = 54,2414 \text{ N s}^2/\text{m}^8/\text{m} \times 15,45 \text{ m} = 838,0296 \text{ N s}^2/\text{m}^8$

For the two air columns that were parallel connected resulting a total of aerodynamics drag is:

$$\sqrt{R_{1-2}} = \frac{\sqrt{R_1} \cdot \sqrt{R_2}}{\sqrt{R_1} + \sqrt{R_2}} = \frac{\sqrt{949,5741} \cdot \sqrt{838,0296}}{\sqrt{949,5741} + \sqrt{838,0296}} \text{ it results that } R_{1-2} = 222,7974 \text{ N s}^2/\text{m}^8$$

In which::  $R_1$ -section 1-2, 2-3, 3-4, 4-5, 5-10;

$R_2$ -section 6-7, 7-8, 8-9;

The total aerodynamic drag of the industrial air-conditioning system has the value – figure no. 1:

$$R_t = R_{1-2} + R_{11-12} = 222,7974 \text{ N s}^2/\text{m}^8 + 4,7927 \text{ N s}^2/\text{m}^8 = 227,5901 \text{ N s}^2/\text{m}^8$$

The unity factor of air loss through column tubes leaks has the following values:

- section 1 –  $K_0 = 3,7548 \times 10^{-3}$ ;
- section 2 –  $K_0 = 1,2786 \times 10^{-3}$ ;
- section 11-12 –  $K_0 = 1,9649 \times 10^{-4}$ ;

The total factor of air loss through column tubes in the industrial ventilation system is:  $K_0 = 1,7432 \times 10^{-3} \text{ m}^3/\text{s}/\text{m}$  la 1 Pa.

In table 2 is synthetically presented the value of the parameters obtained after performing the calculations.

**Table 2.** Calculated aerodynamics parameters

Work Name	Column dimensions Lxl m	Sealing mode	Section length L m	Station NR. 1		Station NR. 2		Unit aerodynamic drag $R_0$ $Ns^2/m^8/m$	The unity factor of air loss through column tubes leaks $K_0$ $m^3/s/m la 1 Pa$
				h <sub>ST</sub> Pa	Q m/s	h <sub>ST</sub> Pa	Q m/s		
0	1	2	3	4	5	6	7	8	9
Ventilation system for chemicals, catalysts and oils CASE NO. I	0,22x 0,16	silico ne gask ets	2,5	98,1	0,099	104,0	0,2608	88,0457	$6,4385 \times 10^{-3}$
	0,2x0,2		4,4	104,0	0,2608	138,3	0,4866	63,231	$4,507 \times 10^{-3}$
	0,2x0,2		4,0	138,3	0,4866	162,8	0,7329	17,8902	$5,0197 \times 10^{-3}$
	0,2x0,2		12,1	162,8	0,7329	247,2	1,1773	8,4109	$2,5697 \times 10^{-3}$
	0,4x0,4		2,5	247,2	1,1773	277,6	1,2045	8,6132	$2,2391 \times 10^{-4}$
	0,17x 0,23		8,45	196,2	0,052	202,1	0,1627	75,3222	$9,598 \times 10^{-4}$
	0,2x0,2		4,5	202,1	0,1627	208,0	0,3314	24,7459	$2,618 \times 10^{-3}$
	0,4x0,4		2,5	208,0	0,3314	225,6	0,3409	62,6562	$2,5809 \times 10^{-4}$
	Φ 300		4,2	451,3	1,553	500,3	1,571	4,7927	$1,9649 \times 10^{-4}$

## 6. CONCLUSIONS

The main role of the industrial ventilation systems is to offer a constant source of fresh air from the outside, to keep the temperature and humidity at comfortable levels, to reduce potential fire and explosive risks and to eliminate and dilute air pollutants;

In order to design and implement an individual ventilation installation one has to meet both comfort and management requirement of the system for the user, without involuntary affecting other functions of the system.

Drag is a geometrical characteristic of conduits / pipes / tubes where air currents flow and is determined by inner surface roughness and irregularity of conduit / pipe / tube walls To determine the aerodynamics parameters which characterize ventilation columns  $R_0$ - unity aerodynamics drag and  $K_0$  – the unity factor of air loss through column tubes leaks, some measurements have been made to a complex industrial ventilation installation which works as an induced ventilation system. After performing calculations and measurements, we have the following statements:

- the airflow conducted by the centrifugal blower correspondent to industrial ventilation installation is  $5592 m^3/h$ , with a depression of 500 Pa;

**Branch no. 1:**

- unit aerodynamic drag  $R_0$  of the column section has large limits values, starting from  $8,4109 \text{ Ns}^2/\text{m}^8/\text{m}$  to  $88,0457 \text{ Ns}^2/\text{m}^8/\text{m}$ , with an average of  $37,2382 \text{ Ns}^2/\text{m}^8/\text{m}$ ;

- average aerodynamic drag of the ventilation column has the value of  $949,5741 \text{ Ns}^2/\text{m}^8$ ;

- airtightness rating of the ventilation column for these branches expressed through the unity factor of air loss through column tubes leaks,  $K_0$ , has registered values between  $2,5697 \cdot 10^{-3} \div 2,2391 \cdot 10^{-4}$ , with an average value of  $3,7548 \times 10^{-3} \text{ m}^3/\text{s}/\text{m}$  to 1 Pa;

**Branch no. 2:**

- unit aerodynamic drag  $R_0$  of the column section has large limits values, starting from  $24,7459 \text{ Ns}^2/\text{m}^8/\text{m}$  to  $75,3222 \text{ Ns}^2/\text{m}^8/\text{m}$ , with an average of  $54,2414 \text{ Ns}^2/\text{m}^8/\text{m}$ ;

- average aerodynamic drag of the ventilation column has the value of  $838,0296 \text{ Ns}^2/\text{m}^8$ ;

- airtightness rating of the ventilation column for these branches expressed through the unity factor of air loss through column tubes leaks,  $K_0$ , has registered values average  $21,7432 \times 10^{-3} \text{ m}^3/\text{s}/\text{m}$  to 1 Pa;

**ACKNOWLEDGEMENTS**

This paper was developed within the Nucleu-Programme, carried out with the support of ANCSI, project no. PN-16-43-02-08

**REFERENCES**

- [1] Alexandru Cristea, Ventilation and Conditioning of Air Volume I, Technical Publishing House, Bucharest, 1968, pp 350-352
- [2] OSH Answers Fact Sheets, Canadian Centre for Occupational Health & Safety – Industrial ventilation Copyright 1997-2017,  
<http://www.ccohs.ca/oshanswers/prevention/ventilation/introduction.html>
- [3] William A. Burgess, Michael J. Ellenbecker, Robert D. 4 Treitman, Ventilation for control of the work environment - second edition - Copyright © 200 John Wiley & Sons, Inc., pp 57-58.  
<http://healthf.kaums.ac.ir/UploadedFiles/jozveh/motalebi/VENTILATIONFORCONTROLTHEWORKENVIRONMENT.pdf>
- [4] Matei, I., Moraru, R, ș.a, Environmental Engineering and underground ventilation, (in Romanian) Technical Publishing House Bucharest, Romania, ISBN 973-31-1496-0 pp. 345-358, 2000.
- [5] Guide for dimensioning the industrial ventilation installations, (in Romanian), INSEMEX Publishing House, ISBN 978-973-88753-4-0, pp. 102-124, 2013.
- [6] F. Băltărețu, I. Matei, Practical guide for designing and review of partial ventilation installations, (in Romanian) la I.P. 13 Dec. 1918, sub c. 106, pp. 39-67, 1987.

- [7] I. Gherghe, D. Cioclea, a.s.o., Methodology of measuring of the air flow rate in the pipelines, (in Romanian), INCD INSEMEX Study, Petroșani, Romania, 2007
- [8] Suvar M.C., Lupu C., Arad V., Cioclea D., Pasculescu V.M., Mița N., Computerized simulation of mine ventilation networks for sustainable decision making process, Environmental Engineering and Management Journal, vol. 13/issue 6, pp. 1445-1451, 2014.

Scientific Reviewer:  
Prof. PhD. Eng. Roland MORARU

## RESEARCH REGARDING FERTILIZATION OF MINING WASTE DUMPS BY USING SEWAGE SLUDGE. CASE STUDY FOR MOTRU AREA

FLORIN FAUR <sup>1</sup>  
MARIA LAZĂR <sup>2</sup>  
IOSIF ANDRAȘ <sup>3</sup>

**Abstract:** *This study was conducted based on the considerations set out in the National Strategy for the Management of Sewage Sludge as well as in the Mining Law and Mining Industry Strategy (focusing on the obligation of ecological restoration of mining waste dumps). In the first part of the paper is briefly described the area where the studied objectives are located (Motru waste water treatment plant (WWTP) and the interior waste dumps of Roșiuța and Lupoia open pits), the characteristics of the deposited material (its origin, the physical and fertility properties), and the chemical composition of the fermented sludge from WWTP Motru. Second part of the study describes the methodology of sampling, the embodiment of the mixture of mining waste rocks and sludge, planting mode and the results of the experiments conducted in vegetation pots.*

**Keywords:** *ecological restoration, fertility, sewage sludge, waste dumps, WWTP*

### 1. INTRODUCTION

This paper represents a study on the possibilities of using the sludge from the WWTP serving the city of Motru for redevelopment of degraded land (in this case the mining waste dumps). The idea of this paper started from two realities facing mining areas in Romania, implicitly the one considered in the study:

1 - in these areas there are large surfaces of land occupied by waste dumps, which are often devoid of vegetation, presenting risk of sliding, are sources of dust pollution and

---

<sup>1</sup> *Assist.prof.dr.eng., Department of Management, Environmental Engineering and Geology, University of Petroșani, Romania, faurfloring@yahoo.com*

<sup>2</sup> *Prof.dr.eng., Department of Management, Environmental Engineering and Geology, University of Petroșani, Romania, marialazar@upet.ro*

<sup>3</sup> *Prof.dr.eng., Department of Mechanical, Industrial and Transportation Engineering, University of Petroșani, Romania, iosif.andras@gmail.com*

gives an unaesthetic aspect to the area where they are located (being often compared with lunar landscapes);

2 - following the integration into the European Union, Romania compelled to solve the problem of waste water treatment, this commitment resulting in the emergence of another problem, namely the management of sludge from WWTP. It is estimated that by 2020 the amount of sludge resulting from waste water treatment will increase about 5 times compared to the one in 2010.

## **2. GENERAL AND LOCAL CONTEXT**

One of the options considered in the National Strategy for Management of Sewage Sludge is the use of it in works of reconstruction of degraded lands. This option of sludge recovery is based on the following considerations [14]:

- the use of sludge in tree plantation and rehabilitation of land quality is accepted by the competent authorities (ROMSILVA, CONVERSMIN etc.);
- forestry and land quality rehabilitation offers - periodically and possibly significant - opportunities to use the sludge, but this directions are not considered safe and continue , and for this reason are not quantified as components of strategies for the use of sludge;
- even if opportunities for use of sludge in forestry and land quality rehabilitation occur periodically, does not significantly affect the estimated costs of the strategy.

Generally degraded lands, implicitly mining waste dumps, lack the layer of fertile soil, and to achieve the fullest possible coverage with sustainable vegetation are used large amounts of fermented sludge originated from WWTP.

This domain of application has a strategic potential for WWTP in Romania, as many of these have important historical stocks of sludge that can be removed in a short period and used in different areas for land quality rehabilitation and ecological restoration.

The land surfaces requiring ecological reconstruction works, implying restoration of their quality in terms of fertility are: former industrial sites, mining waste dumps and tailing ponds, quarries and closed landfills. Such types of land are common in Romania, legacies of the industrial past, and the imperative of their rehabilitation lies in the need to control pollution and restore environmental quality.

For mining industry there is a legal obligation to restore the land when the activities are ceased and return them to the status of functional ecosystems or to reintroduce them into the economic circuit.

Around 45% of the total area occupied by mining deposits, over 4,000 ha, are represented by waste dumps of coal mining, mainly lignite and hard coal (139 deposits located in 13 counties) [4].

These sites represent a significant potential for the use of sludge. If the entire surface of the mining deposits would be rehabilitated by applying 50 t DS/ha of sludge, the amount required would be equal to the annual output of sludge in Romania [14].



Motru municipality is located in the south-west part of Gorj County (Romania) at the demarcation line between Mehedinți and Gorj Counties. The total geographical area of Motru Municipality is of 50.09 km<sup>2</sup> of which 14.293 km<sup>2</sup> urban areas.

The waste water treatment plant (WWTP) Motru is located in the south of the city and has been modernized in recent years (is designed to serve a population of 28,000 inhabitants while the current population of the municipality Motru and belonging villages connected to the sewage network is of 22,848). The two open pits (Lupoia and Roșiuta) are part of Oltenia Energetic Complex, serving CTE Turceni.

### **3. CHARACTERISTICS OF THE MINING WASTE DUMPS**

In the present study there were considered the two interior waste dumps belonging to Lupoia and Roșiuta open pits, neighboring Motru municipality, north of it.

#### **3.1. Origin of the waste material**

The sterile material consists of rocks from the overburden of the lignite deposit mined in the two open pits, as well as from sterile intercalations.

Motru mining basin located in the western segment of the Dacic Basin is a intracontinental lacustrine sedimentary basin. Structurally, the most part of Motru mining basin is located over the Carpathian Foredeep, the sector in front of Middle Carpathians, and to a lesser extent over the Moesian Platform. The evolution of the Dacian Basin as a carbon-generator basin can be traced during Lower Dacian until the inferior period of the Middle Romanian (in the present research the Jiu-Motru formation presenting importance).

The lithological composition of Jiu-Motru formation, of lignite strata and clay formations, is characterized by a great diversity of clay types: predominantly gray-purple clays, white clays (in dry state), but also other colors and shades (brown, green and blackish), carbonaceous clays, sandy clays, red and gray clays. To these formations are added silts, sandy silts, silty sands and sands which have cross-stratification, typical to fluvial deposits [7].

#### **3.2. Technological processes and their influence on land**

Under the determining influence of geological, mining and economic conditions, the lignite deposits from Motru mining basin are operated by 2 open pits (Lupoia and Roșiuta).

The process of extracting lignite in open pits includes the following operations: selective excavation, transport, deposition of waste rocks in dumps and deposition lignite in storage facilities.

Excavation is performed in a continuous flux by bucket-wheel excavators, types: SRs1300, SRs1400, SRs2000, in steps with heights of 25-30 m (Fig. 1) [9].



**Fig. 1.** Mining operations in Lupoia open pit

The excavated material is transported by conveyor belts, having a width of 1,000 – 2,250 mm and maximum speed of 6.15 m/s, and the transport capacity reaches 12,500 m<sup>3</sup>/h. Deposition of waste material dump is performed by installations with flow rates ranging from 2,500 to 12,500 m<sup>3</sup>/h, the length of the discharge boom ranging between 60 and 170 m [5].

Among the negative effects on the natural environment, resulting from the exploitation of lignite by open pit mining, the most important are changing the morphology of the landscape and the internal structure of the ground on depths between 2 and 200 m, to which degradation and/or destruction of soils is added, the two effects being connected to each other.

The volume of works necessary for rehabilitation and reconstruction of areas affected by mining and related costs have a negative influence both on technical and economic indicators of mining and on the environmental quality indicators.

### **3.3. Characteristics of the waste material**

The sterile mass in which are located the layers of lignite from Oltenia mining basin comprises a mixture of clays and sands of various types. Clays have the largest share in the deposits containing lignite layers and they present a wide range of subtypes, which are distinguished by mineralogical features, chemical composition, granulometry, color, organic matter content, etc. [11]. The variation limits of physical and geotechnical properties of different formations present in the composition of waste dumps are very large.

The loosening coefficient of the rocks present in the two interior waste dumps ranges between 1.34 and 1.56.

The grain size of waste material (average for the two interior dumps) is presented in table 1.

*Table 1. Average granulometry*

<b>Grain size classes</b>	<b>Content (%)</b>
- clay (below 0.005 mm)	23.5 – 29.3
- dust (0.005 – 0.05 mm)	15.4 – 24.1
- sand (0.05 – 2.0 mm)	18.5 – 24.2
- gravel (2.0 – 20 mm)	13.3 – 23.9
- boulder (over 20 mm)	5.3 – 6.4

It can be observed from the table that there is a balance in terms of content of clay, dust, sand and gravel, while boulder fraction (over 20 mm) is found in the analyzed samples in a much lower percentage.

The main feature, crucial in obtaining anthropogenic soils is the chemical composition, especially the phosphate content.

Analysis carried out on clays collected from different mining perimeters from Oltenia basin highlighted the fact that clays with higher phosphate content of 0.18%  $P_2O_5$  (up to 2.73%  $P_2O_5$ ) are found in four clay packages with variable thickness, well individualized and spatially located.

Stratigraphic position of the four packages is identified from under layer V of lignite where is located the first package with concentrations of  $P_2O_5$  ranging between 0.2% - 1.2%. Subsequently the next clay package is located on top of layer VI of lignite, then the clay package located on top of layer VII and the clays package located between layers XIII and XIV of lignite, the average concentrations of  $P_2O_5$  in these three packages exceeding 1% [12].

By color, the clay package situated between layers XIII and XIV of lignite is individualized, showing pinkish reflections, the remaining packages of clays having common colors.

Spatial positioning of the clay packages rich in  $P_2O_5$  situated on top of the lignite layers is genetically explained by the existence of lakes with basin-wide development installed over the carbon-generating swamps. In these lakes there was a high concentration of humic substances which favored the occurrence of phosphorus minerals [12].

The total thickness of  $P_2O_5$ -rich clay deposits is appreciated to be of approx. 21 m, representing 59% of the total amount of clays that compose the waste rocks from the two open pits (Lupoia and Roșiuța).

A characteristic of clays from Oltenia mining basin is the presence of variable amounts of humic matter (humus), which reaches values between 0.96% and 18.12%, explaining the gray and dark gray colors of most of the clays.

In order to determine the possibilities of substitution of natural soils in areas affected by mining extraction process, a comparative analysis was conducted between the physical and chemical characteristics of the  $P_2O_5$ -rich clays and natural soils present in the area (Tab. 2).

Table 2. Fertility characteristics of the deposited material [12]

Characteristic	Clays	Recovered soils	Soils from Romania
Mineralogical content	smectite - illite	smectite - illite	diverse
Humus	0.90 – 18.12	1.02 – 12.96	-
Nutritive substances			
Phosphorus (P <sub>2</sub> O <sub>5</sub> ) %	0.031 – 2.73	-	0.12 – 0.18
Mobile phosphorus (ppm)	23 - 174	12 - 91	-
Potassium (K) %	0.10 – 2.76	-	0.97 – 3.43
Calcium (Ca) %	1.07 – 11.83	-	1.1 - 5
Hydrogen potential			
pH	7.26 – 8.20	4.68 – 8.05	5.8 – 8.2
Description	neutral- weak alkaline	acid - weak alkaline	weak acid - weak alkaline

Analyzing the characteristics presented in Table 3, to which may be added isolated empirical experimentations, it can be stated that the clays (present in the two interior waste dumps) have many qualities and may be used to replace recovered soils.

For the clays to contribute to the supply of elements with fertility properties, able to support vegetation, is needed a reconfiguration of the current technological fluxes, so that their storage is carried out selectively in the upper part of the final steps of the dumps (possibly through the construction of intermediate deposits).

Such a substantial change of existing technological fluxes involves time and significant financial resources allocated for this purpose, which would add supplementary economic pressure on the operator (Oltenia Energy Complex).

#### 4. QUALITY OF SEWAGE SLUDGE

Sludge quality is an important factor to determine feasible options for sludge management. Characterization of sewage sludge is extremely important prior to sludge disposal or application to land because there is a risk of toxic elements accumulation [13].

##### 4.1. Chemical analyses

Because we referred to the National Strategy for Management of Sewage Sludge, and it imposes certain quality conditions for the sludge from WWTP depending on the type of use, table 3 presents the results of laboratory analyzes performed between February and May 2016 (by spectrofotometry).

Although the values of quality parameters of sewage sludge from the SEA Motru are below the limitations set by regulations in force (Order No. 344/2004), the values of certain parameters does not recommend its use in agriculture, but at the same time makes it suitable for ecological restoration of degraded lands.

Table 3. *Quality parameters of the sludge from WWTP Motru*

Parameter	Max. admitted conc. cf. Order 344/2004	Date	22.02	22.03	23.04	22.05
		MU	Determined values			
pH	-	pH unit	7.68	7.53	7.74	7.33
moisture	-	%	80.98	82.8	79	81.2
loss on calcinations	-	%	58.77	61.8	65.15	65.5
total nitrogen	-	mg/kg ds	432	905.95	924	542.76
total phosphorus	-	mg/kg ds	9226	10373	17464	11146
potassium	-	mg/kg ds	2691	3864	4800	5237
arsenic	10	mg/kg ds	5.7	5.1	4.91	5.4
cadmium	10	mg/kg ds	4.55	3.04	2.42	2.98
total cyanide	-	mg/kg ds	<1	<1	1.14	<1
cobalt	50	mg/kg ds	10.2	8.36	8.99	7.88
total chromium	500	mg/kg ds	97.7	95.2	94.6	99.6
copper	500	mg/kg ds	420	250	482	319
mercury	5	mg/kg ds	0.83	0.9	0.14	0.28
nickel	100	mg/kg ds	68	65.2	67.4	68.5
lead	300	mg/kg ds	80.4	66.7	71.7	73
zinc	2000	mg/kg ds	131,7	108,3	167	104.8
total PAH	5	mg/kg ds	2.26	3.08	2.35	3.58

Another important aspect that can be noticed in table 3 is linked to the high content of nutrients, namely nitrogen, phosphorus and potassium. These values indicate that the digested sludge from WWTP Motru has a high capacity to increase the fertility of degraded lands.

An important parameter, pH has neutral-weakly alkaline values, this also recommending the use of sewage sludge in works of ecological reconstruction of degraded lands (eliminating the risk of acidifying or alkalizing the waste material).

#### 4.2. Concerning issues

The use of sewage sludge for fertilization of land in general can lead to unwanted effects on the environment. The most frequent encountered problems are related to possible contamination of soil (in this case of the waste material from the dumps) and water (both surface and groundwater).

Certain risks are associated with the use of sludge due to its possible contamination with:

- heavy metals (cadmium, lead, arsenic, etc.);
- disease-causing organisms (bacteria, viruses, parasites);

- toxic organics (such as PCB's and pesticides).

As shown by Damian et al. [2]; Big et al., [1] and Lassoued et al. [8], although the application of sludge promotes the productivity of the land, it is usually accompanied by an accumulation of heavy metals. Most of the metals accumulate in the surface horizon which presents a limit to this practice [10].

In general, the concentrations of heavy metals are lower in seeds compared to other plant organs.

However, this problem is not so acute in the case of ecological restoration works (especially by forestation) as this process doesn't aim at obtaining crops (used in food industry or animal farming) that may lead to acute or chronic intoxications.

In Motru mining basin the primary goal of ecological restoration is represented by the rapid reintegration of the mining waste dumps in the surrounding landscape, so the possible accumulation of heavy metals is of little concern at present.

The other major concern is related to water resources in the area that may be contaminated with different substances.

Nitrate has been found to leach into the surface or groundwater from sludge application sites whenever the amount of nitrogen applied is greater than that needed for fertilizing the plants. This is also true for commercial fertilizers and manure, if present in excess. A small or infrequent leaching of nitrates may be considered acceptable at some sites [6].

Careful management of sludge can minimize these risks and objections. Depending upon sludge quality, characteristics of the application site and the intended use of the material, some or all of the following safeguards may be needed:

- pretreatment programs to protect sludge quality;
- monitoring of soils, groundwater and runoff;
- limited annual and total heavy metal application;
- appropriate site selection and choice of plants;
- control of soil acidity;
- limited public access to the application site;
- heat treatment of the sludge.

## **5. THE EXPERIMENTS**

Given those presented so far, in connection with the difficulty of modifying the existing technological fluxes, and considering the fertility properties of the sludge from WWTP Motru, next, the paper presents the results of some experiments conducted in vegetation pots (in the summer of 2016). For this purpose there were followed the steps presented below.

### **5.1. Sampling of mining waste rocks and sewage sludge**

The mining waste rocks that were used in the experiments were taken from the interior dumps of the two open pits from Motru Basin (Lupoia and Roșiuța).

Initially, three samples were taken from each waste dump, from different working steps, each of approx. 50 kg. The material thus collected (approx. 300 kg) was then homogenized on site and the sample was reduced in successive stages to 10 kg.

This sample, considered to be representative for the waste dumps was transported to the University of Petroșani in order to conduct experiments in vegetation pots (also this material was used for particle size determination).

The digested sludge from the drying platform of WWTP Motru was collected in nylon bags, from areas of recent deposition.

Reduction of samples down to 10 kg was carried out on site by the same process of successive quartation, after which the material was also transported to the University of Petroșani.

### 5.2. Mixing the waste material and digested sewage sludge

Having the samples collected and processed it was raised the problem of establishing a system of fertilization of mining waste with digested sewage sludge in vegetation pots. The mixtures of mining waste and digested sludge included the following samples:

- P1 - 100% waste material;
- P2 - 75% waste material and 25% digested sludge;
- P3 - 50% waste material and 50% digested sludge;
- P4 - 25% waste material and 75% digested sludge;
- P5 - 100% digested sludge.

These mixing options were considered based on the results of a previous study [3].

The amount of mixture from the vegetation pots was of approx. 250 g. The mixing itself was done manually in a larger vessel, depending on the quantities required.

### 5.3. Experiments in vegetation pots

Figure 2 shows images of the vegetation pots during planting, germination and development. There were used two types of grains, wheat respectively barley. To facilitate observations in each vegetation pot there were planted 10 seeds.





**Fig. 2.** Vegetation pots: A) immediately after planting; B) after 5 days; C) after 15 days; D) after 30 days (top row wheat, bottom row barley, the pots are numbered from 1 to 5 from left to right)

During the 30 days of experiment there were made observations on the number of plants emerged and their development.

In the period after planting, depending on the proportions of materials from the pots, the number of seeds that sprout was different.

During the period of growth and before the end of the experiment there were observed slight differences in the rate of growth and the height reached by the plants.

## 6. RESULTS AND CONCLUSIONS

The observations on the development of plants are summarized in tables 4 and 5 and figures 3 A and B. As can be seen, both types of seeds used sprouted in satisfying proportions.

*Table 4. Percentage of grown plants (Wheat)*

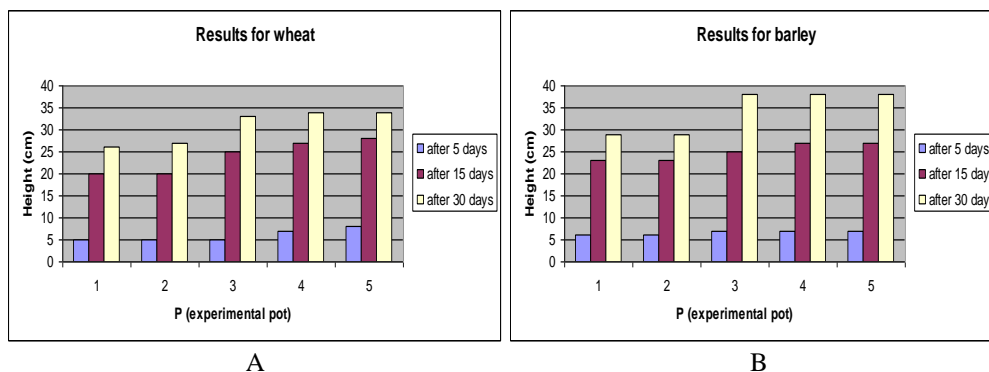
Day	Wheat				
	P <sub>w1</sub>	P <sub>w2</sub>	P <sub>w3</sub>	P <sub>w4</sub>	P <sub>w5</sub>
Day 5	40%	40%	50%	60%	60%
Day 15	40%	40%	60%	60%	60%
Day 30	40%	40%	60%	60%	60%

*Table 5. Percentage of grown plants (Barley)*

Day	Barley				
	P <sub>w1</sub>	P <sub>w2</sub>	P <sub>w3</sub>	P <sub>w4</sub>	P <sub>w5</sub>
Day 5	30%	40%	60%	60%	50%
Day 15	30%	50%	60%	60%	60%
Day 30	30%	50%	60%	60%	60%

Thus, even in the pots containing only sterile material the plants germinated and grew in satisfactory number and relatively apace with those planted in pots with different mixtures of waste rocks and digested sludge.





**Fig. 3.** Height of the plants along the experiment: A) wheat; B) barley

This can be explained by those presented in paragraph 3.3, that the sterile material from the dumps contains clays with fertility properties that can provide some nutrients for plants (the plants developing on waste dumps usually grow slower and they don't reach maturity).

However it can be seen a higher percentage of sprouting and germination, faster growth and more vigorous plants obtained in the pots with mixtures of sterile rocks and digested sludge.

These issues are highlighted by the superior proportions in which the seeds have germinated (60% compared with 40% for wheat and 60% compared to 30% for barley) and by the length of the plants at the end of the experiments (33 - 34 cm compared with 26 cm for wheat and 38 cm compared with 29 cm for barley).

Comparing the results from the pots with 50 - 50% mixture of waste material and digested sludge to those with higher proportions of digested sludge, they are almost identical. This leads to the idea that in order to successfully use the sludge from WWTP Motru in works of ecological restoration of degraded land (mining waste dumps), the inferior limit of the sterile-sludge mixture necessary to obtain satisfactory results is 50 - 50%.

As the ecological restoration of the interior mining waste dumps of Lupoia and Roșița open pits aims at forestry re-cultivation, is recommended that the digested sewage sludge to be applied on the entire surface of the dumps and to be incorporated into them to a depth of 2 m (ensuring a fertile sub layer on the entire rooting depth).

To validate the results obtained from the experiments in vegetation pots there are necessary field experiments (with saplings) conducted under less or uncontrolled conditions.

Using the sewage sludge from WWTP Motru in ecological restoration of mining waste dumps solves the problem of sludge management in the area according to the legislation in force.

Also, this type of use is more economically efficient as the costs of transporting the sludge from the WWTP to the waste dumps are significantly smaller than those involved to the deposition of the sludge in ecological landfills.

## REFERENCES

- [1] Big, C.A., Lăcățșu, R., Damian, F., *Heavy metals in soil-plant system around Baia Mare city, Romania*. Carpathian Journal of Earth and Environmental Sciences, 7 (3), pp. 219-230, 2012.
- [2] Damian, F., Damian, Gh., Lăcățșu, R., Macovei, Gh., Iepure, Gh., Năprădean, I., Chira, R., Kollar, L., Rață, L., Zaharia, D.C., *Soils from the Baia Mare zone and the heavy metals pollution*. Carpathian Journal of Earth and Environmental Sciences, 3 (1), pp. 85-98, 2008.
- [3] Faur, F., Lazăr, M., Pop, D.M., *Research on obtaining a substitute topsoil for ecological reconstruction of mining waste dumps*. Proceedings of the 16<sup>th</sup> International Multidisciplinary Scientific GeoConference SGEM. Book 5, Vol. 1, pp 577-584, 2016.
- [4] Fodor, D., *Mining and environment*. Corvin Deva Publishing House, 356 p. (in Romanian), 2015.
- [5] Fodor, D., Vulpe, I., Lazăr, M., *Technical and technological rehabilitation of the lignite open pits*. Infomin Publishing House, 270 p. (in Romanian), 2003.
- [6] Hope, J., *Sewage sludge disposal and utilization study*. Washington State Institute for Public Policy. Document No. 86-01-4101, 27 p, 1986.
- [7] Huidu, E., Scorțariu, O., *Oltenia mining monography*. Măiastra Publishing House, Vol. IV, 604 p. (in Romanian), 2008.
- [8] Lassoued, N., Bilal, E., Rejeb, S., Guenole-Bilal, I., Khelil, M.N., Rejeb, M.N., Gallice, F., *Behavior canola (Brassica Napus) following a sewage sludge treatment*. Carpathian Journal of Earth and Environmental Sciences, 8 (3), pp. 155-165, 2013.
- [9] Lazăr, M., Faur, F., *Considerations on the influence of extraction technology of lignite in open pits over the production quality*, Proceedings of the 12<sup>th</sup> International Multidisciplinary Scientific GeoConference SGEM. Surveying Geology & Mining Ecology Management, pp 503-510, 2012.
- [10] Nyamangara, J., Mzezewa, J., *The effect of long-term sewage sludge application on Zn, Cu, Ni and Pb levels in a clay loam soil under pasture grass in Zimbabwe*, Agriculture, Ecosystems & Environment, 73 (3), pp. 199–204, 1999.
- [11] Rotunjanu, I., *Stability of natural and artificial slopes*. Infomin Publishing House, 351 p. (in Romanian), 2005.
- [12] Scorțariu, O., Guran, I., Lazăr M., *Obtaining anthropogenic soils from waste rock for reclamation of damaged land by coal pits from Oltenia*. Proceedings of the 22<sup>nd</sup> World Mining Congress. Vol. 4, pp. 3–9, 2011.
- [13] Usman, K., Khan, S., Ghulam, S., Khan. M.U., Khan, N., Khan M.A., Khalil, S.K., *Sewage sludge: an important biological resource for sustainable agriculture and its environmental implications*. American Journal of Plant Sciences, 3, 1708-1721, 2012.
- [14] General Direction “AM POS Mediu” (GDAPM), *National strategy for management of sewage sludge, Part II (Final version)*, 92 p. Project code: POSM/6/AT/I.1.2010, (in Romanian), 2011.

Scientific Reviewer:

Assoc. Prof. PhD. Eng. Emilia-Cornelia DUNCA

## IMPLEMENTATION OF SUSTAINABLE PRACTICES IN THE LIGNITE OPEN PIT ROSIA DE JIU

APOSTU (NYARI) IZABELA MARIA <sup>1</sup>  
LAZĂR MARIA <sup>2</sup>  
FAUR FLORIN <sup>3</sup>

**Abstract:** *Exploitation of lignite in Rosia de Jiu open pit can be included in the broad concept of sustainable development through the development and integration of practices that lead to minimizing the environmental impact of mining operations. In this paper are analyzed solutions such as: rational exploitation of the deposit, reducing water and energy consumption, reducing the amount of affected land, preventing environmental pollution and ensuring the rehabilitation and reuse of degraded land. Thus, the land affected by mining can be reused for the development of sustainable activities in order to obtain the best results in terms of environment, community and economy.*

**Keywords:** *environment; land rehabilitation; land reuse; open pit; sustainability.*

### 1. INTRODUCTION

Rosia Jiu open pit, through its location in the region, the morphology of the terrain, the size of the mining area, the development of mining works, large volumes of industrial reserves, difficult geomining and hydrogeological conditions, relatively high reports between overburden and lignite, represents a base study for analyzing operating practices and reusability of the land after the closure of mining activities in the context of sustainability.

In Rosia Jiu open pit, the first mining works were started in 1973. After more than four decades of exploitation there were extracted over 100 millions t and in 2015 the available reserves were estimated at 21.5 million t.

Mining can become sustainable through the development and integration of practices that lead to minimizing the environmental impact of mining operations. These practices include measures to reduce consumption of water and energy, the amount of land affected, prevention of environmental pollution and measures for closure and rehabilitation of the area. (Laurence et al., 2011).

---

<sup>1</sup> *PhD. Student University of Petrosani izabelamaria.nyari@yahoo.com*

<sup>2</sup> *Prof. Dr. Eng. University of Petrosani*

<sup>3</sup> *Assist. Dr. Eng. University of Petrosani*

## **2. IMPLEMENTATION OF SUSTAINABLE PRACTICES THROUGHOUT THE LIFECYCLE OF THE OPEN PIT**

Since mining activity in Rosia de Jiu open pit is viable for another decade, it requires the implementation of sustainable practices in relation to the exploitation of the resource available, to be effective, primarily in terms of environmental protection, health and safety of population, but also economically.

### **2.1. Rational and total exploitation of the lignite deposit**

Complete extraction of lignite reserves and the quality of the extracted coal, are priority issues concerning the rational exploitation of deposits. In these circumstances, recovery of coal from the final slopes of the pit and from thin layers is in question.

In the first case, the method of extraction with Auger-Mining type drills can be applied. It consists in drilling of large diameter executed in the definitive slopes of the open pit, allowing recovery of coal at the rate of up to 60%, reserves which, under current operating conditions, remains untapped, representing also a financial loss. (Lukhele, 2002).

Coal mining from the final slopes of the open pit is conducted after sizing the drilling holes and security pillars, very important for the stability of the slope. After extracting the coal, the remaining holes in the slopes will be filled with sterile material from waste dumps.

In the second case, it is recommended the use of surface combines, which, due to the configuration of the extraction system have a higher degree of selectivity than conventional extraction machinery (bucketwheel, mechanic shovel, backhoe excavators etc.). By using surface combines, layers with small and very small thickness can be extracted selectively without lowering productivity. The extracted material is loaded and transported by trucks. (Lazăr, 1998)

The use of surface combines, in particular for the extraction of thin layers, has two important advantages: due to substantially reducing operating losses, the recovery of reserves is increased by 25%; separate extraction of sterile insertions with small thickness considerably improves the quality of extracted coal, leading, among other things, to a reduction in processing costs.

The technique of extracting coal by milling gives the material a particle size less than 150 mm, which corresponds to the requirements imposed by transport on conveyor belts and requirements imposed by power plants.

Other advantages of surface combines, in terms of beneficiaries include: creating a clean working surface; the possibility of depositing directly the sterile derived from insertions; ability to use the equipment not only for extraction but also as auxiliary equipment.

## 2.2. Implementation of water spraying devices mounted on bucketwheel excavators

Following the operations needed to extract the resource, results large amounts of dust that lead to degradation of air quality. This in turn leads to increased risk of illness to employees and local communities situated at relatively small distances from Rosia open pit (Farcasesti Moşneni village at about 250 m, Rosia village and residential area of Rovinari town at about 700 m).

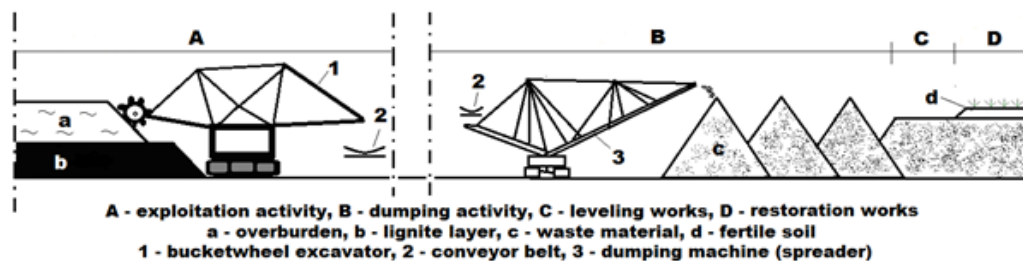
Splashing water on sterile materials and lignite, manipulated in the open pit, from excavation to deposition, aims to reduce the amount of dust and particulate mater from air, by maintaining a sufficient humidity of materials that do not allow to be driven by wind. (forum.bulk-online.com).

The method consists in implementing sprayers mounted on bucketwheel excavators, dumping machines (spreaders), loaders and on conveyors.

The advantage of this system is represented by the reduction of the amount of dust and particulate maters in the atmosphere, with the possibility of using poor quality water. The costs to implement this system in Rosia de Jiu open pit are relatively low and the benefits are considerable.

## 2.3. Restoration of land while exploiting

In order to recover and reuse lands affected by mining from the operating stage, restoration of land is recommended to be carried out while exploiting (fig. 1), by the immediate start of reconstruction and rehabilitation processes of the areas freed from their technological tasks. (Nyari and Lazăr, 2016).



**Fig. 1.** Restoration of land while exploiting

This practice presents important advantages, such as reducing the period of rehabilitation of the area of land affected after closure of the open pit, reducing the degree of pollution of the environment, gradual reintegration of land in the adjacent landscape and the possibility to reuse of the rehabilitated land for other purposes.

## **2.4. Reuse of waste material**

Waste rock resulting from the extraction of lignite in Rosia de Jiu open pit, are made of clay, sand and gravel and they contain no hazardous substances.

The waste material can be used as filler in the construction of highways and the rough fraction can be used as embankment to protect riverbanks, to ensure the stability of natural and artificial slopes and reinforce dams.

The advantages are represented by the reduction the amount of waste material deposited and thus the surfaces of natural lands occupied, and by the reduction of the amount of construction materials exploited.

## **3. IMPLEMENTING SUSTAINABLE PRACTICES AFTER CESSATION OF MINING ACTIVITIES**

Lignite resources from Rosia de Jiu open pit are sufficient only for the next 10 years. Given the fact that the local economy will be affected by its closure, is essential to recover the affected land and return it to the natural or economic circuit.

In this regard, the paper analyzed three land reuse solutions that can contribute to sustainable development of the region (that can be adapted for other similar regions):

- reconstruction and ecological rehabilitation of degraded land;
- construction of a photovoltaic park;
- implementing a system for collecting and recycling municipal waste.

By 2015, the open pit occupies 392.3 ha, the interior dump 573 ha, and the exterior dump 493 ha. It was chosen for the photovoltaic park to be constructed on the interior dump and in the open pit, while the remaining premises in the mining perimeter to serve for collection and recycling of municipal waste. Since the exterior waste dump is already restored (forestry plantation), it is recommended the maintenance and monitoring of the works.

### **3.1. Reconstruction and ecological rehabilitation of degraded land**

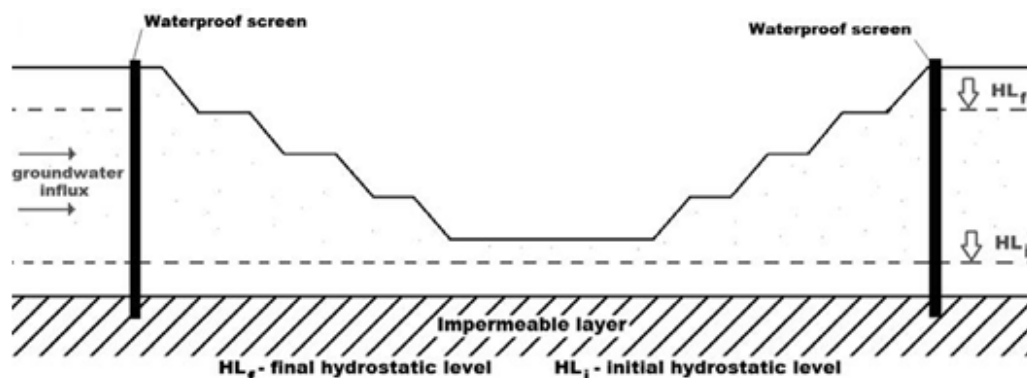
After exploitation works, the land must be released from its technological tasks and of the decommissioned constructions at risk of collapse or that can not be used in future economic activities.

Before the land is reused, its rehabilitation and recovery is necessary, through a complex process that involves insurance of physical, chemical and biological stability of the degraded land, reshaping the land in order to increase the stability of the pit and waste dumps slopes and its reintegration in the adjacent landscape, deposition of a layer of topsoil and its amendment in order to improve soil quality and, not least, revegetation of the land depending on the type of reuse.

Recovery and rehabilitation of land in the mining area of Rosia de Jiu open pit, for the development of a photovoltaic park, does not require special environmental conditions. There are needed stabilization, leveling, reshaping and terracing works to reduce the inclination of the open pit's and dump's slopes, so that rolling or collapse of rocks are not be triggered, and at the same time to ensure the location and optimal operation of photovoltaic panels. Minimal recovery processes are sufficient, which involves improving environmental quality, so that adjacent ecosystems and local communities are not affected.

Taking into account the proposals for future activities, it is recommended grassing of the land with an important role in erosion control and soil binding. However, in marginal areas, it is recommended the plantation of vegetation curtains for land protection against wind erosion, land stabilization and improvement of water regime. Revegetation is made after a layer of topsoil is deposited and amended order to improve quality and ensure optimal conditions for maintaining the vegetation.

To restore the hydrostatic level of groundwater in adjacent areas and to protect the remaining hole in which the photovoltaic park will be constructed it is suggested the construction of waterproof screens around the mining perimeter (fig. 2). Recovery of the hydrostatic level by natural means may take a long time, but there is the possibility of accelerating this process by injecting water behind the impermeable screens, through a reverse dewatering process. ([www.geoengineer.org](http://www.geoengineer.org))



**Fig. 2.** Restoration of hydrostatic level of groundwater using waterproof screens

After the land is recovered, it requires maintenance and its necessary to monitor the environmental components, to determine and eliminate potential sources of pollution and their negative impacts.

### 3.2. Construction of a photovoltaic park

Lignite exploitation was the basis for production of electricity, at national level, by its integration in the National Energy System, for supply of industry and

population. With the closure of Rosia de Jiu open pit, but also from other lignite open pits in the country which have reserves available for the next 20-40 years (as a result of the mining sector restructuring process), reduces the amount of lignite extracted and thus the amount of electricity produced from it.

Solar energy is the energy produced directly by the transfer of light energy radiated by the Sun and can be used both for domestic consumption to generate electricity or to heat the air inside buildings and nationally, through the occupation of large areas of land in order to supply the National Energy System. Solar panels generate electricity and, at the same time they store energy in batteries to be used when solar energy is inefficient.

Given that solar potential in Romania has remarkable values and that in most developed countries in Europe (even in those with solar potential lower than in Romania) electricity production based on energy of sunlight is successful, it can be stated that the development of a large photovoltaic park in our country, would be a major step towards sustainability. In this regard, an important aspect is the represented by the insurance of environmental and community protection.

For the case study of Rosia de Jiu open pit, it can be considered as an advantage the possibility of occupying a large area of land, approximately 1,000 hectares (considering the space available currently and extension until closure), given that one of the largest solar parks in Romania occupies an area of approximately 150 ha (near Sebiş, Arad county), and the largest photovoltaic park in the world, located in the Mojave desert, California, occupies an area of 1600 ha.

Each element of the complex that constitutes the photovoltaic park has a well defined role:

- photovoltaic panels capture solar energy;
- energy is taken up by a junction box from a series of panels;
- the generator connection box takes energy from more junction boxes;
- energy is transformed from DC to AC by a triphasic inverter;
- through an electrical station the energy is transmitted to the National Energy System. ([www.anpm.ro](http://www.anpm.ro))

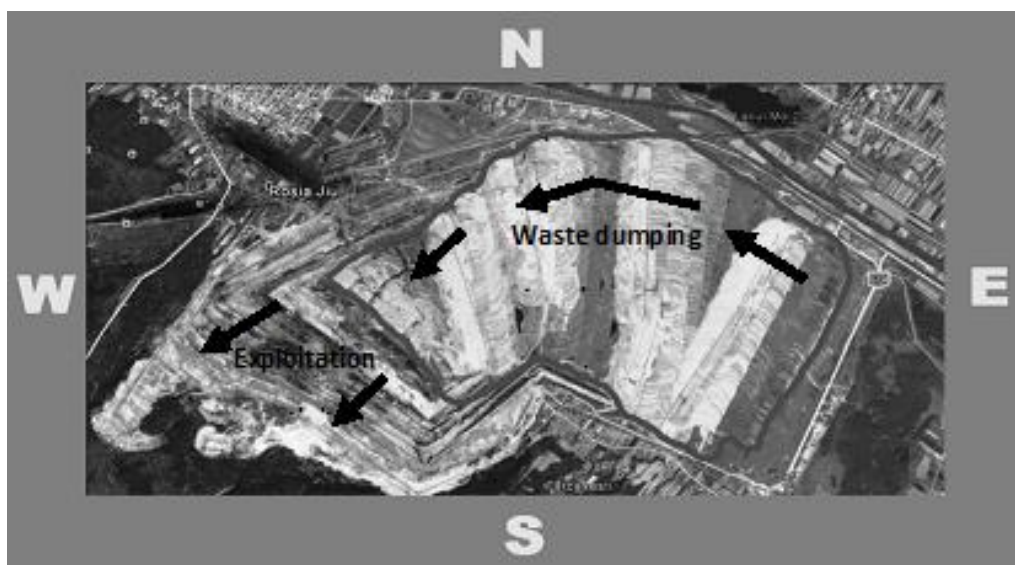
The construction of the photovoltaic park involves the following: construction of access roads for maintenance processes and enclosure fences, installation of steel structures, cables and panels, mounting connecting stations and transforming stations with inverters.

In 2011, the company BoDean operating in quarrying, was the first company in the world that functioned entirely on electricity produced by its own system of photovoltaic panels mounted on the closed and recovered steps of the open pit. ([www.rockproducts.com](http://www.rockproducts.com))

Starting from this idea, for Rosia de Jiu open pit is proposed installing the panels on the steps exposed to the south, where the incidence of sunlight is highest, and on the interior waste dump so that solar radiation is perpendicular on the solar collector. On slopes with northern exposure are recommended to fit the connecting stations and transforming stations with inverters, and the unoccupied surfaces should



be grassed or even planted with trees or shrubs, if they do not jeopardize the smooth operation of photovoltaic panels (fig. 3).



**Fig. 3.** Surfaces available for the construction of the photovoltaic park depending on their orientation

Given the approximately 1,000 hectares at disposal, and taking into account both the variability worldwide of the percentage of actual occupation of the land by panels and other structures necessary for the development and optimal operation of the park, namely 35 - 90%, and morphological conditions of the land occupied by Rosia de Jiu open pit, it is proposed the minimum effective occupation of the land (with the possibility of increasing the occupancy) as follows:

- $\approx 300$  ha - photovoltaic panels;
- $\approx 50$  ha - connecting station, substation and inverters, driveways for maintenance works and fences;
- $\approx 650$  ha - green spaces.

Recently in Romania, in Timis county, was built a photovoltaic park on an area of 44.14 ha (located within the locality Bencecu de Sus) which consists of 84,480 photovoltaic panels, with an installed capacity of 20 MW, the contribution to the National Energy System is estimated at 25,628 MWh/year (25.6 GWh/year). Compared to these values, results that the area available in Rosia de Jiu mining perimeter (1000 ha, of which 255 ha actually filled with panels), involves the installation of approximately 1.7 million photovoltaic panels with an installed capacity of 374 MW, which under a clear sky at a rate of 40-50% per year and an average of 9 hours of light per day, would allow to supply the National Energy System with approximately 500-600 GWh/year.

The advantages are considerable and include: regenerative capacity of the resource, production of electricity without negative environmental impacts, long life, easy operation, high resistance.

The disadvantages are represented by the impossibility to provide constant energy due to the alternation of day and night or on cloudy days, the high cost of installation (with the advantage of generating free of costs electricity through the system's lifecycle) and occupation of large areas of land.

Even if initial investments are impressive, such a project can provide large amounts of electricity, and the costs can be balanced over time. This system significantly reduce harmful gas emissions resulting from electricity generation in traditional power plants and, not least, being clean energy, participates and supports the sustainable development of the society.

### **3.3. Construction of a municipal waste recycling center**

Increasing recycling of reusable materials reduces the consumption of natural resources and, therefore, the level of pollution of the environment. Municipal wastes consist of: paper, cardboard, plastic, glass, aluminum, wood, electrical and electronic equipments, waste from parks and gardens, biodegradable fractions and waste from construction and demolition. Recycling from waste involves an intermediate processing of materials (sorting, shredding and/or compaction), transport, recovery of materials and final processing.

The center for municipal waste recycling will occupy the existing premises and will manage waste from nearby localities. Premises available from Rosia de Jiu open pit occupy about 6 ha and can be used in carrying out sorting, crushing and baling. Transporting them to entrepreneurs specializing in recovery and final processing of waste can be done by rail or road. Development of the collecting infrastructure must be made so that the value of recovered materials to cover the costs of collecting, processing and transport.

To increase the degree of recycling is recommended to implement efficient systems or centers of selective collection of municipal waste in each locality, as well as educating, encouraging and empowering people regarding the need for recycling. Waste collection can be done by taking waste directly from the manufacturer (collected on categories) by a company that processes them, either by transporting waste to collection centers by the producers themselves.

The main advantages consist in conservation of natural resources and reduction of waste storage facilities. A complex center for collection and recycling of household waste can contribute to the sustainable development of society through the application of appropriate management and waste processing practices, having positive effects on the environment, community and local and even national economy.

### 3.4. Alternative solutions for land reuse

Implementing the solutions listed above is a correct and rational choice, allowing the reuse of the land affected, bringing benefits to local communities through the production of renewable energy, replacing the amount of energy produced from lignite, when mining operations in Rosia de Jiu open pit will stop, but also by encouraging recycling and reusing of waste, actively participating in resources conservation and reduction of municipal waste deposited.

A major problem is that the mining basin is part of an agricultural area with high productivity while being an area with high potential of solar energy. Conditions in the location and morphology of the land, the adjacent ecosystems and communities, allows reusing the land for other purposes. Here are some alternatives:

- *Productive reuse.* The land affected by mining is part of highly productive farmland. Before starting lignite exploitation activities, the mining area was occupied lands destined for forestry and agriculture (arable and grassland), so when the approved of exploitation rates are achieved, the land may be remodeled and reconstructed, so it may go back into the productive economic cycle.
- *Recovery for recreation and leisure.* The land, being near inhabited areas, can be reused for recreation and leisure. The residual hole of the open pit will be filled with water to create a mirror of water (lake) and in parallel with the construction of specific structures for the upcoming destinations (which can be a place of picnic, camping, sports etc.) will recreate the natural landscape with green areas, forests, positive landforms and various elements necessary in shaping the landscape. In this case, the construction of underground waterproof screens is no longer required.
- *Recovery for controlled landfill.* Uncontrolled growth in the quantity of household and/or industrial waste requires the allocation of new spaces for storage. Storing waste on land areas already degraded is a rational choice, especially where there is a residual hole, whose physical, chemical and biological characteristics allow its use for this purpose in conditions of maximum security for the environment and community. (Lazăr, 2010)

So choosing the best solution requires numerous ecological, economic and technical analyzes and studies, consultation of local communities being essential, so that the type of reuse chosen to have the capacity to meet their needs, bringing long-term benefits.

## 4. CONCLUSIONS

Sustainable development aims at the constant improvement of quality of life and well being of present and future generations by empowering society, creation of sustainable communities able to manage rationally natural resources and promoting the reduction of the ecological footprint. This can be accomplished by encouraging

reduction of resource consumption, increasing recycling and reuse of waste and minimize the extent of damage and pollution of the environment by applying the best practices of mining and management of natural resource.

A mining exploitation must be efficient in terms of resource management, so it needs a mining management team composed of experts from different fields to work together in adapting, changing and modernizing technologies and current practices, leading the development of a eco-efficient mining, satisfactory in terms of profitability and gentle in terms of environment and community.

For choosing solutions to reuse lands affected by mining there are necessary ecological, economical and technical analyzes and surveys, to establish exactly what is the best solution. For the reuse of land it is essential to consult local communities, so that the type of reuse will have the ability to meet their needs, bringing long-term benefits. The solutions presented are fair and reasonable options that can be applied globally, allowing exploitation of mineral resources by applying sustainable industrial practices and recovery and reuse of land, after reaching operating quotas, for activities capable of reaching the primary objective: sustainable development.

## REFERENCES

- [1]. Lukhele M. J., *Surface auger mining at Rietspruit Mine Services (Pty) Ltd, The Journal of the South African Institute of Mining and Metallurgy*, SA ISSN 0038-223X/3.00+0.00, (2002).
- [2]. Laurence, D. et al., *A guide to leading practice sustainable development in mining*, ISBN: 978-1-921812-48-4 (paperback)/978-1-921812-49-1 (online PDF), Australian Government, Department of Resources, Energy and Tourism, (2011).
- [3]. Lazăr, M., *Recovery and capitalization of thin lignite layers from Oltenia open cast mining perimeters (in romanian)*, Doctoral thesis, University of Petrosani, (1998).
- [4]. Nyari, I-M., Lazăr, M., *Extraction of lignite from Oltenia in the context of sustainable development (in romanian)*, 15<sup>th</sup> National Symposium for Students "Geoecologia", MEdCN, University of Petrosani, Faculty of Mining, ISSN 1842-4430, Petrosani, (2016).
- [5]. <http://forum.bulk-online.com/showthread.php?23616-Innovative-Dust-Suppression-Device>
- [6]. [http://www.anpm.ro/anpm\\_resources/migrated\\_content/uploads/107353\\_Evaluare%20impact%20Foto%201\\_Pischia.pdf](http://www.anpm.ro/anpm_resources/migrated_content/uploads/107353_Evaluare%20impact%20Foto%201_Pischia.pdf)
- [7]. <http://www.geoengineer.org/education/web-based-class-projects/geoenvironmental-remediation-technologies/impermeable-barriers?start=1>
- [8]. <http://www.rockproducts.com/technology/automation-a-energy/13120-stellar-energy-looks-to-the-solar-system-for-quarry-operations.html#.V8adblt97IU>

Scientific Reviewer:  
Prof. PhD. Eng. Mircea GEORGESCU

## **SURFACE SUBSIDENCE PROGNOSIS IN THE CASE OF LONEA MINE USING KNOTHE BUDRYK INFLUENCE FUNCTION**

**RAMONA-RAFILA MARIAN<sup>1</sup>**

**Abstract:** *The phenomenon of surface subsidence occupies an important place in the activity of mining researchers both locally, in the Jiu Valley mining basin, and worldwide. The research of this phenomenon is of particular importance, especially due to the need to protect the surface and the civil or industrial constructions existing in the area. For this purpose, over time, have been developed a multitude of methods for the prognosis of surface displacement and deformation, methods successfully applied especially in the case of stratiform deposits. Among this methods is the influence function method, applied in this paper for the prognosis of surface deformation due to the underground mining of coal in the case of Lonea Mine, Jiu Valley mining basin.*

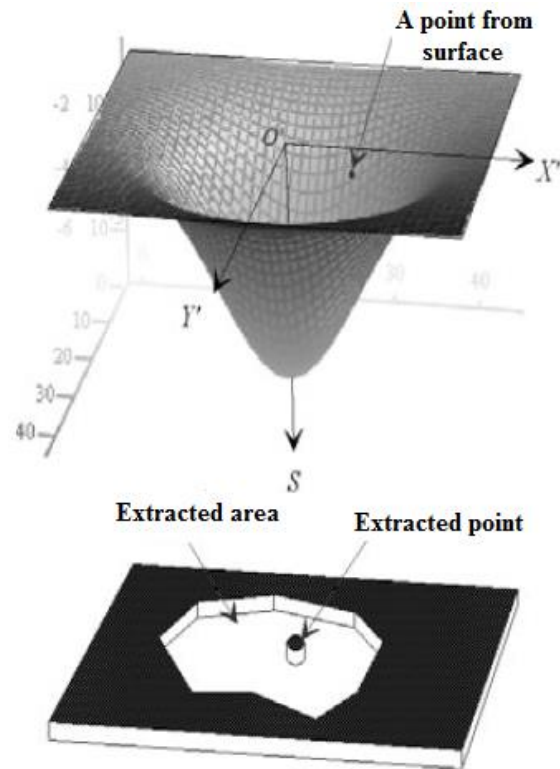
**Key words:** *surface, subsidence, underground mining, influence function, monitoring*

### **1. GENERALITIES ABOUT THE INFLUENCE FUNCTION METHODS**

Influence functions are part of the set of empirical methods applied to predict the surface deformation as a consequence of underground mining. Unlike the profile function method [5], [8], the influence function method can be applied in the case of multiple extracted areas, or to areas with difficult configuration [6]. The influence function methods are based on the prognosis of the configuration of subsidence trough using the theory of the influence area around an extracted point (figure 1) [4], [5], [7]. These methods can be applied in the case of extracted areas of different shapes, but they are much more difficult to calibrate and verify than the profile function methods.

---

<sup>1</sup> *Min. Eng. Ph.D. Student at the University of Petroșani*



**Figure 1.** Principle of influence function method [3]

The influence function whose point of maximum subsidence is vertically located can be well represented by Knothe's theory:

$$f_s(x, y) = \frac{W_{\max}}{R^2} e^{-\pi \left( \frac{x^2 + y^2}{R^2} \right)} \quad (1)$$

Or, for an extracted area delimited by coordinates  $x_1$  and  $x_2$ , subsidence is given by:

$$W(x, y) = \frac{W_{\max}}{R} \cdot \int_{x_1}^{x_2} e^{\left[ -\pi \cdot \frac{x^2 + y^2}{R^2} \right]} \cdot dx \quad (2)$$

where:  $W_{\max} = m \cdot a \cdot \cos \alpha$ ;  $m$  is the thickness of the extracted seam;  $a$  – subsidence factor ( $a = 0,7 \div 0,98$  for methods of directing the pressure through total collapse of the rock from the roof);  $\alpha$  – seam inclination;  $x, y$  plane rectangular coordinates;  $R$  – main radius of influence ( $R = H / \tan \beta$ );  $H$  – mining depth;  $\beta$  – angle of influence.

The horizontal displacement is assumed to be proportional to the first derivative of the subsidence and can be calculated with the relation [10]:

$$U(x) = B_s \cdot \frac{W_{\max}}{R} \cdot e^{\left[-\pi \cdot \frac{x^2}{R^2}\right]} \quad (3)$$

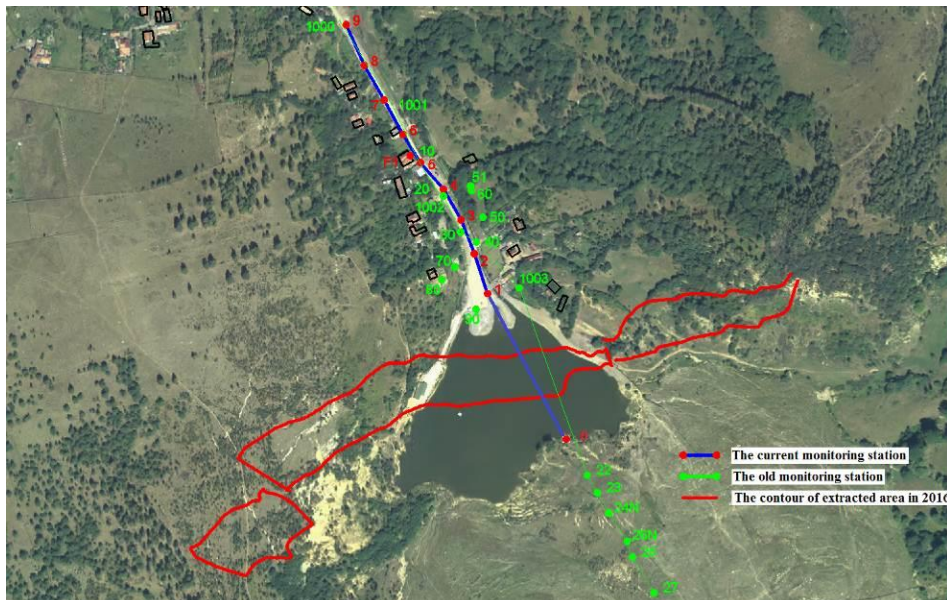
where:  $B$  is a coefficient of horizontal tensions.

## 2. SURFACE SUBSIDENCE MONITORING IN THE CASE OF LONEA MINE

In the case of Lonea mine, surface is affected by the underground mining of the coal seam no. 3, with inclination of about  $30^\circ$  and a thickness of 28-42m, in downward horizontal slices, with the directing the pressure through total collapse of the rock from the roof.

In the case of this mine, the monitoring of surface deformation was performed along time intermittently (during the period 1985-1992 there was a maximum subsidence of about 16m [9], during the period 2008-2015 has been measured a maximum subsidence of 1.2m) due to the disappearance of the benchmarks which forms the monitoring station, for which there is no clear situation with regard to the size of total displacement of the surface [1], [2].

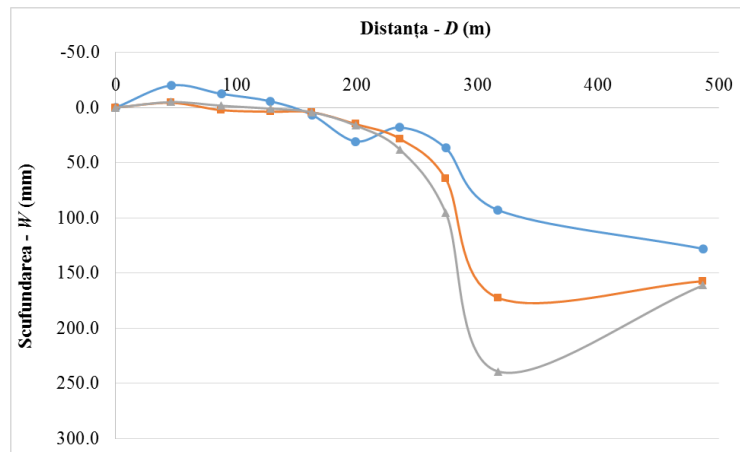
In 2016 has been materialized a new monitoring station, located approximately in the same location as the previous one (Figure 2) [6].



**Figure 2.** Plane position of the monitoring station at Lonea mine [6]

On this monitoring station the observations were performed starting with 2016 and so far have been made four measurements. To determine the altitude of the benchmarks has been applied the middle geometric leveling method and to determine the coordinates has been used the total station and the GPS. The arrangement of the benchmarks has been made transverse to the coal seam.

In the figure 3 are represented the subsidence curves measured so far.



**Figure 3.** Surface subsidence curves measured at Lonea mine [6]

As can be seen, the surface is affected by the underground mining of the coal. Also, the constructions located in the affected area (Lonea, Defor area) still suffer considerable movements, manifested by cracks and massive destruction of the walls (Figure 4).



**Figure 4.** Buildings affected by the underground mining a) 07.1.2016 b) 26.10.2016



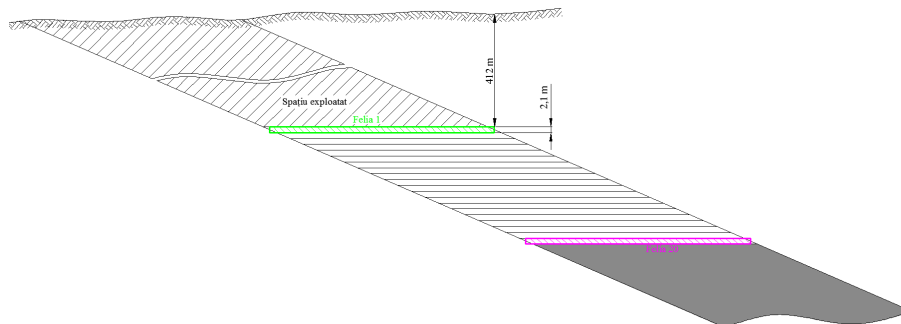
Also, the effects of the underground mining can easily be observed, from place to place at the surface appearing significant shifts and cracks (Figure 5).



**Figure 5.** Surface affected by the underground mining

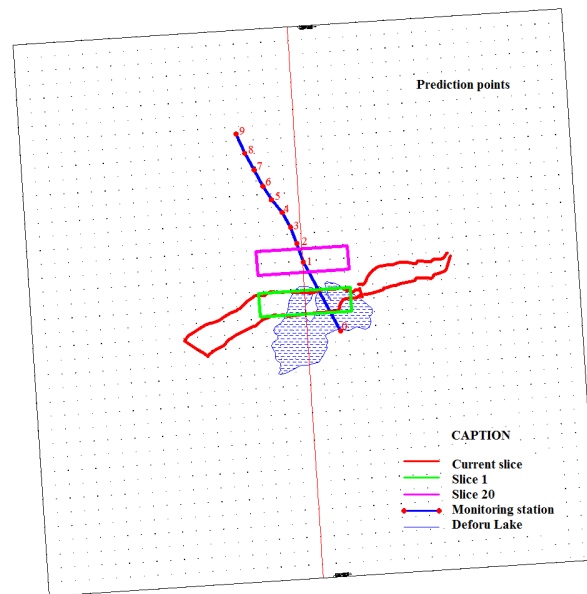
### 3. APPLYING THE KNOTHE-BUDRYK INFLUENCE FUNCTION IN THE CASE OF LONEA MINE

For the prognosis of surface deformation in the case of Lonea mine, using the influence function method, has been considered the underground mining in horizontal slices (the extraction of 20 slices, figure 6), starting from a mining depth of 412m (ignoring the effect of the past underground mining), with a thickness of the slice of 2.1m.



**Figure 6.** Vertical section trough seam no. 3, Lonea mine

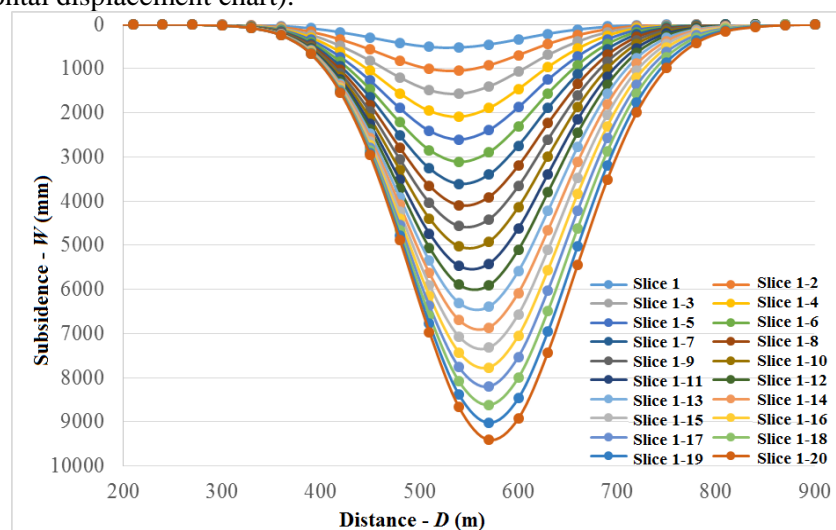
For simplicity, was considered a rectangular shaped extracted area, which best approximates the extracted space in the area of interest (Deforu zone and the constructions from the area), leaving from his margin a distance of 500m to the limit of the predicted area (Figure 7).



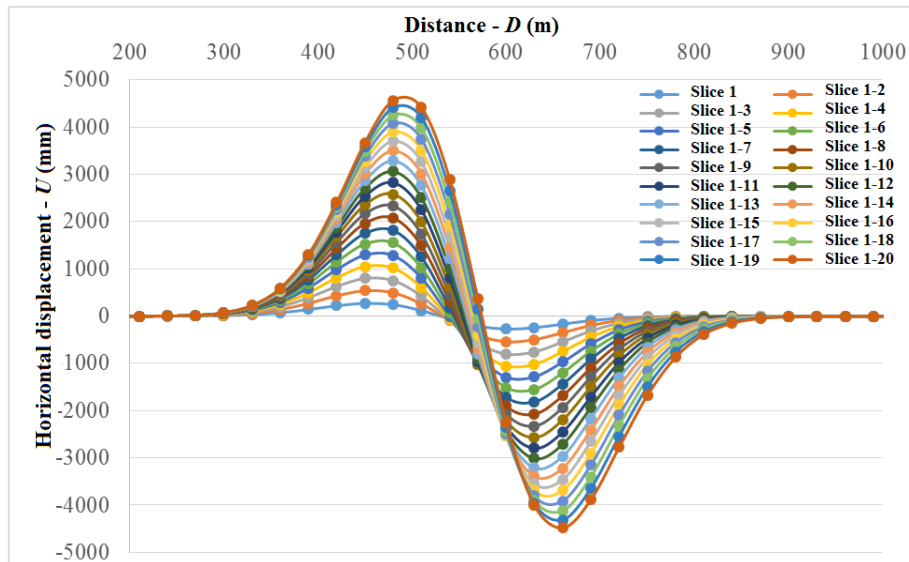
**Figure 7.** Surface subsidence prognosis using influence function method, Lonea mine

For the prognosis of surface deformation as a result of underground mining, Knothe's influence function method was applied, using the Excel and AutoCAD software's to interpret the results.

The prognosis of the development of subsidence trough in time, with the complete extraction of each slice is shown in figure 8 (subsidence chart) and in figure 9 (Horizontal displacement chart).

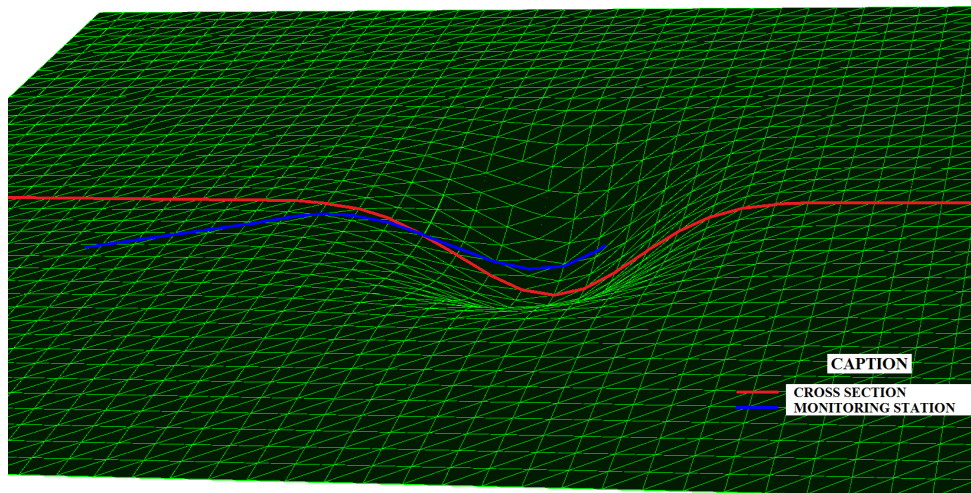


**Figure 8.** Surface subsidence prognosis in time with the complete extraction of each slice

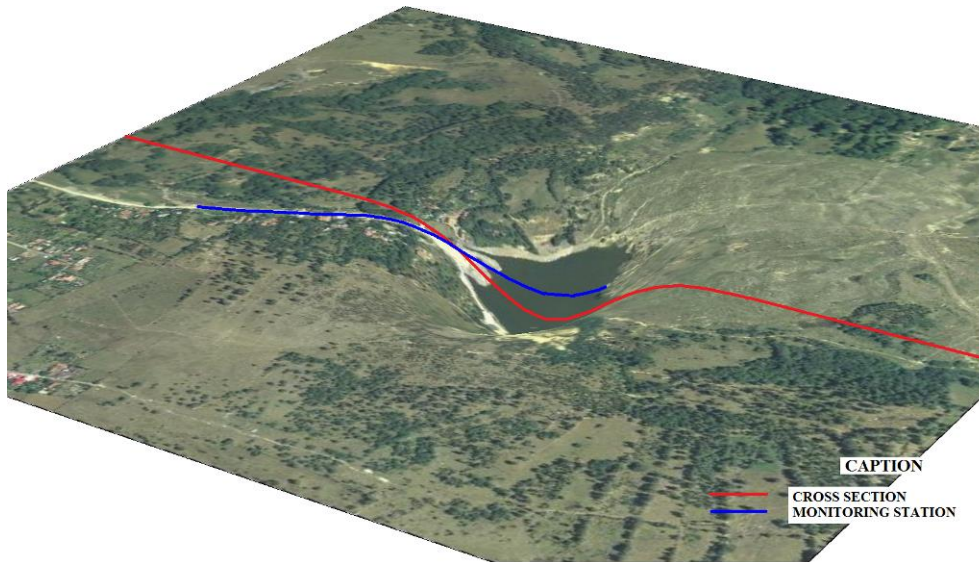


**Figure 9.** Surface horizontal displacement prognosis in time with the complete extraction of each slice

In figures 10 – 11 is represented the 3D subsidence trough forecast at the final stage of the extraction (the extraction of all 20 slices).

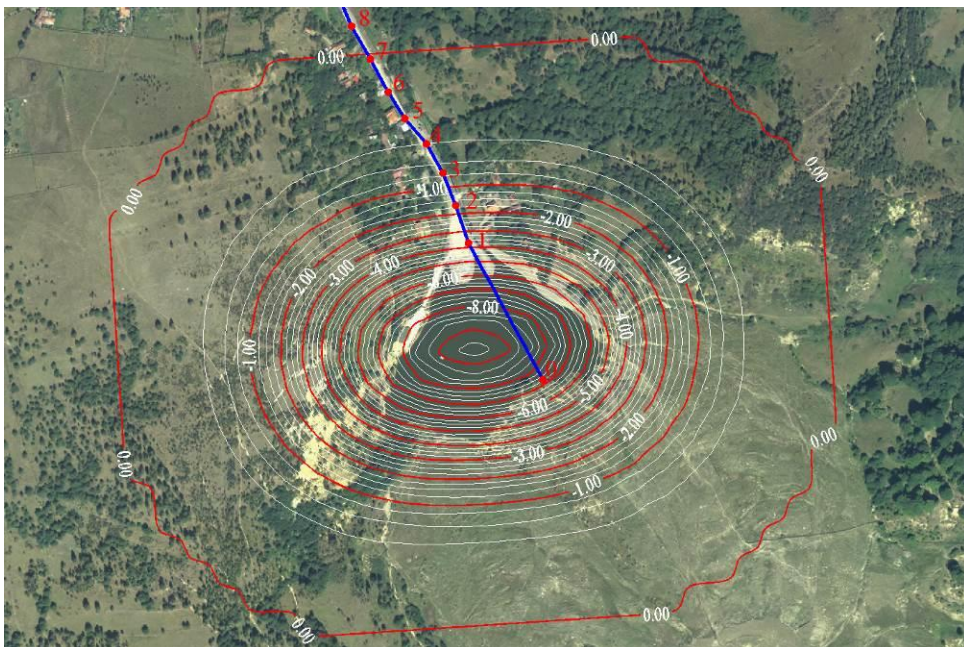


**Figure 10.** Predicted subsidence trough at Lonea mine

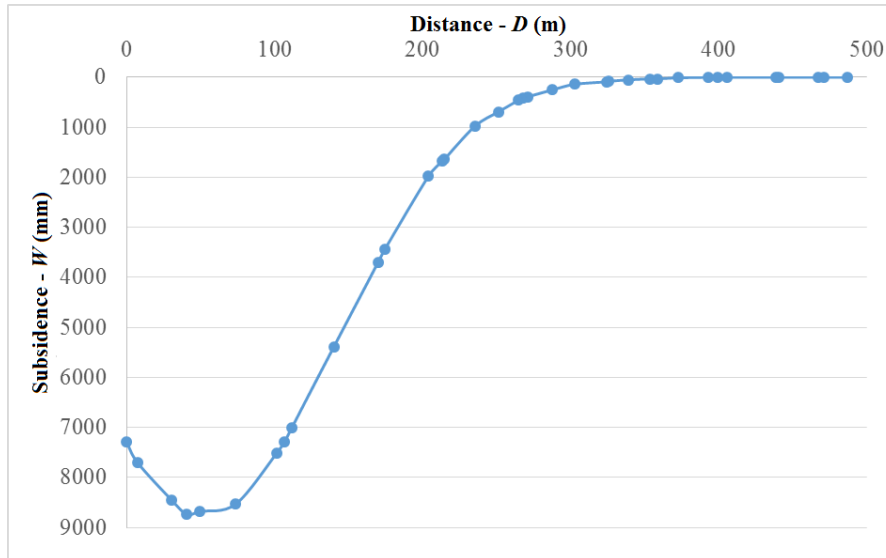


**Figure 11.** Predicted subsidence trough at Lonea mine

For a better estimation of the size of surface and the construction subsidence, equal subsidence curves were generated (Figure 12) and a vertical section was made through the monitoring station from the surface (Figure 13).

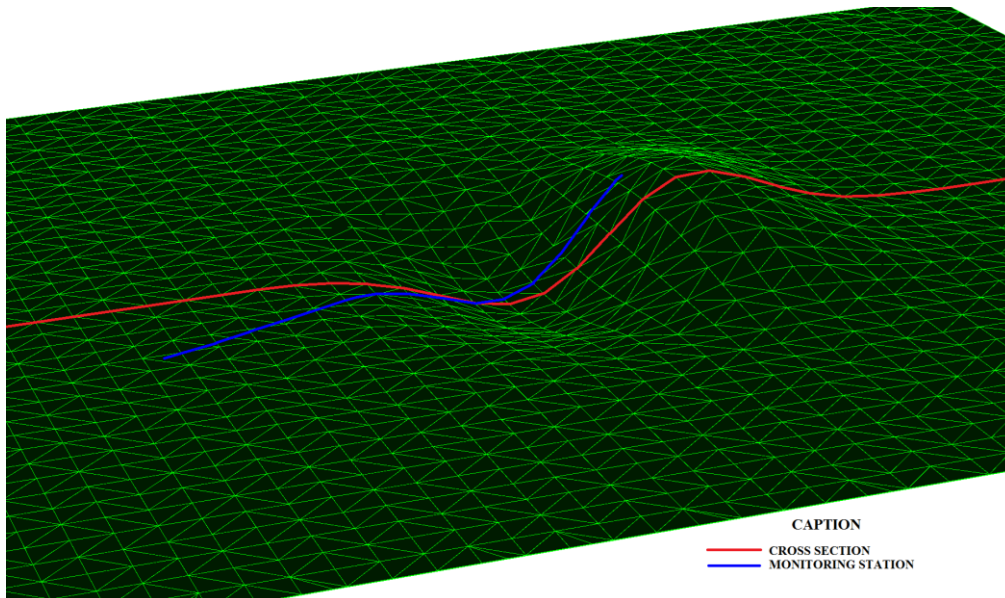


**Figure 12.** Predicted equal subsidence curves

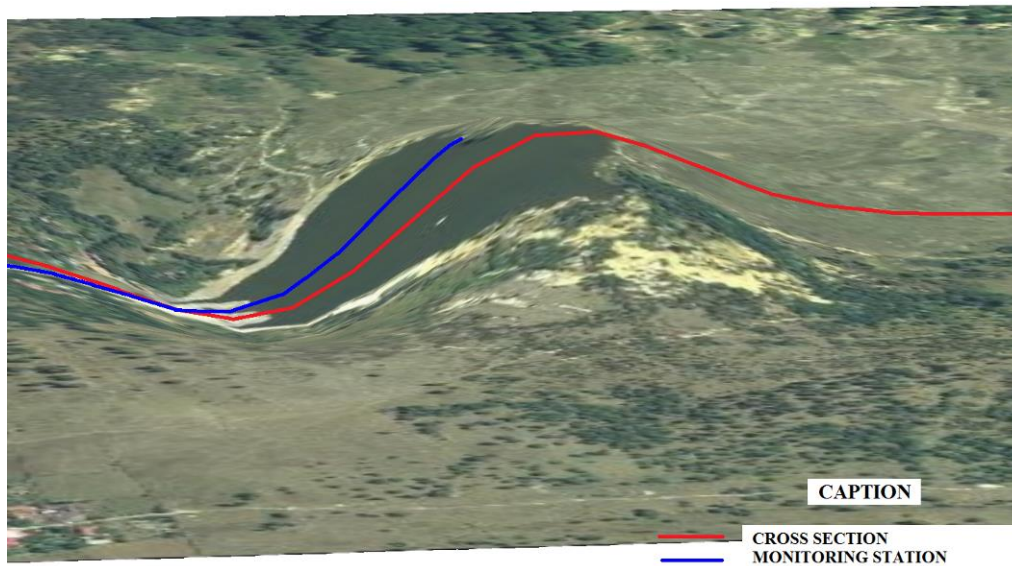


**Figure 13.** Predicted subsidence through the monitoring station

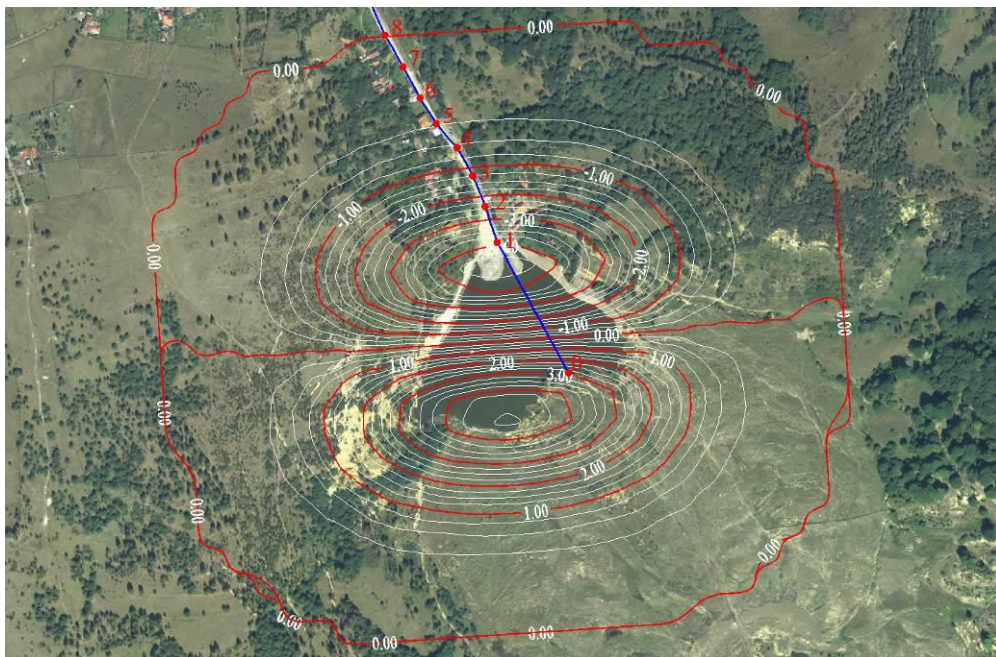
It was also predicted the horizontal displacement along the X axis (considered approximately on the direction of the monitoring station) shown in figures 14-17.



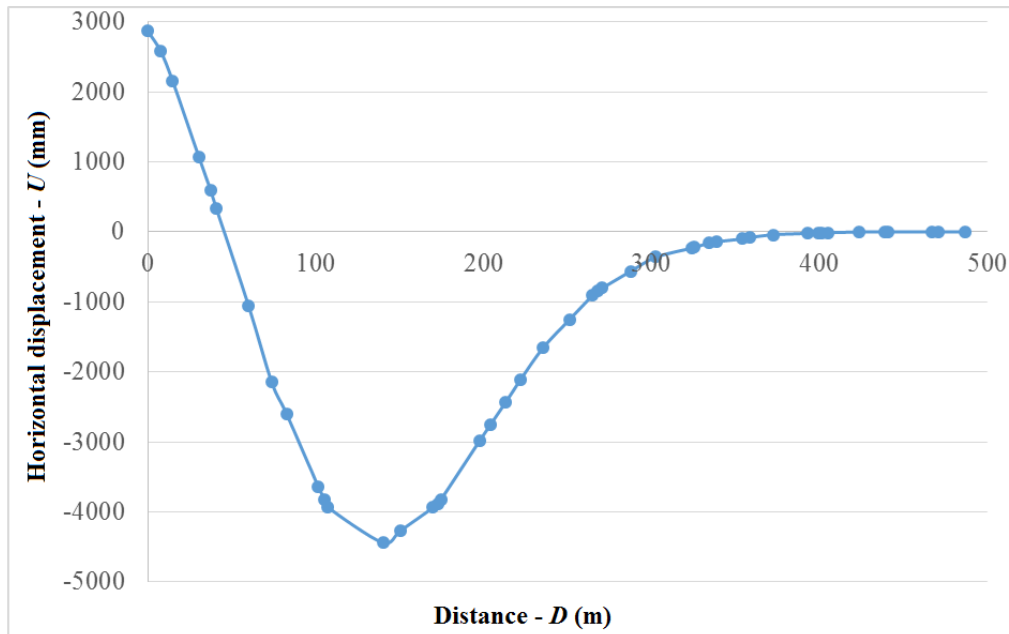
**Figure 14.** Horizontal displacement after X axis predicted for Lonea mine



**Figure 15.** Horizontal displacement after X axis predicted for Lonea mine



**Figure 16.** Equal horizontal displacement curves after X axis predicted for Lonea mine



**Figure 17.** Horizontal displacement after X axis through the monitoring station predicted for Lonea mine

#### 4. CONCLUSIONS

Researching the influence of underground mining on the surface and constructions which exists in the area of influence, is necessary in order to highlight the phenomenon of subsidence and to take measures to protect the objectives and the surface on which they are builded.

As can be seen from the horizontal and vertical displacement graphs, over time, the entire monitoring station will be affected by the underground mining, the benchmark's considered stable reaching the boundary of the area of influence. This is why it will be necessary to prolong it.

Regarding the constructions in the area, they will be greatly affected by the underground mining, which is also visible at the moment.

If in practice it was proved by topographical measurements that the subsidence trough resulted due to underground mining of the seams with medium and large tilt is asymmetric, due in particular to the sliding of the rocks after the stratification planes, in the case of the predicted subsidence trough by the influence function method it can be seen that this has a slight asymmetry due to a significant advance on the depth of the extraction.

Finally, analyzing the results obtained from this study, we can say that the influence function methods provide an overview of the subsidence phenomenon,

however, as can be seen from the graphs presented, these functions cannot fully capture the complex deformation phenomena of the rock mass from the extracted seam to the surface, especially in the case of the seams with high tilt (such as the Lonea mine case).

## REFERENCES

- [1]. Floarea, D.A., Marian D.P., Onica, I., Cozma, E. – *Necessity of Following up the Land Surface Deformation For Closed Mining Areas*, International Multidisciplinary Scientific GeoConference SGEM, Sofia, Bulgaria, 2015.
- [2]. Floarea D., Onica I., Cozma E., Marian D.P. – *Necessity of Subsidence Phenomenon Monitoring in the case of Sustainable Development of Jiu Valley Coal Basin Conditions*, Annals of the University of Petroșani – Mining Engineering –, Vol. 15 2014.
- [3]. Luo, Y., Peng, S., Zhu, Z. - *Upgraded Comprehensive and Integrated Subsidence Prediction Model CISP – W*, West Virginia University Morgantown, WV, 2008.
- [4]. Marian, D.P. – *Analiza stabilității terenului de la suprafață sub influența exploatării stratelor de cărbuni cu înclinare mică și medie din bazinul Văii Jiului*, Teză de doctorat, Universitatea din Petroșani, 2011.
- [5]. Marian D.P. – *Urmărirea topografică și analiza deformării suprafeței terenului afectat de exploatarea subterană*, Editura Universitas, Petroșani, 2012.
- [6]. Marian R.R. – *Comportarea construcțiilor de la suprafață aflate în zona de influență a exploatării subterane a stratelor de cărbuni*, Raport de cercetare nr. 2, Universitatea din Petroșani.
- [7]. Onica, I., Marian, D.P. - *Ground surface subsidence as effect of underground mining of the thick coal seams in the Jiu Valley Basin*, the Archives of Mining Sciences, Vol. 57, no. 3, 2012, p. 547-577; ISSN: 0860-7001.
- [8]. Onica, I., Cozma, E., Marian D.P., Ștefan N. – *Prognosis of the Maximum Subsidence and Displacement of the Ground Surface in the Jiu Valley Coal Basin Conditions*, International Multidisciplinary Scientific GeoConference SGEM, Sofia, Bulgaria, 2014.
- [9]. Ortelecan, M. – *Studiul deplasării suprafeței sub influența exploatării subterane a zăcămintelor din Valea Jiului, zona estică*, Teză de doctorat, Universitatea din Petroșani, 1997.
- [10]. [http://update.carlsonsw.com/public/sdps\\_qref.pdf](http://update.carlsonsw.com/public/sdps_qref.pdf)

Scientific Reviewer:  
Assoc. Prof. PhD. Eng. Ioel VEREȘ



## DETERMINATION OF GEODESIC POINTS IN CASES OF INDETERMINATION

IOEL VEREȘ<sup>1</sup>

**Abstract:** *The development of geodetic and topographic networks requires the determination of provisional or definitive coordinates of new points called densification points. The known and applied methods sometimes lead to cases of indetermination, on which, a solution is proposed in the present paper through which, the final results are obtained with relatively good accuracy.*

**Keywords:** *angular intersection, resections, indetermination, topographical points, accuracy*

### 1. THE IMPORTANCE AND PURPOSE OF THE PAPER

The development of triangulation networks is important for a multitude of engineering works in different fields of activity. Network development consists in determining the coordinates of new points, called densification points, in order to increase the density of known points on a given surface. Based on the national geodetic network, from close to closer, according to the principle of passing them higher order to the lower order, new points are determined, judiciously chosen, which will be used in the area in detail work.

There are several ways to determine new points. The present paper deals with the process of determining the points through the resection. Resection is a relatively simple and fast method, but in using of this method there are also situations in which the precision of the results is very low or even situations of indetermination are encountered.

The purpose of this paper is to provide a solution for non-determination cases that can't be solved by known methods.

### 2. CASES OF NON-DETERMINATION

Known methods for resolving resections do not provide good results if the densification point is close to the circle determined by the three known points and if the densification point is in the circle determined by the three known points then there

---

<sup>1</sup> *Assoc. Prof. PhD. Eng. University of Petroșani*

is a non-determination. For example, in the case shown in Figure 1 there are known points A, B, C and point P must be determined. There are an infinity of points located on the AC arc from which the same angles  $\alpha$  and  $\gamma$  are observed in relation to the points A, B and C. If point P is not even on the circle passing through points A, B, C but it is close to this circle, and if the processing is done by the Tienstra method (barricentric coordinates) [1], [2], [3], then:

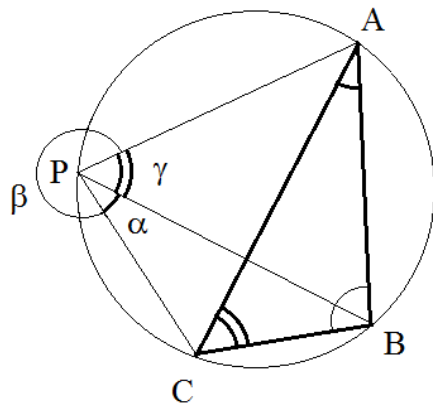


Figure 1.

$$\alpha \cong A, \gamma \cong C \quad (1)$$

and

$$ctg A - ctg \alpha \cong 0$$

$$ctg C - ctg \gamma \cong 0 \quad (2)$$

$$ctg B - ctg \beta \cong 0$$

For this reason weights tend towards  $\pm\infty$ , and the coordinates obtained as weighted media have big errors.

When using the Collins method [1], [3], (fig.2) if point P is on the circle, then Collins' auxiliary point Q is even confused with point B, making it impossible to

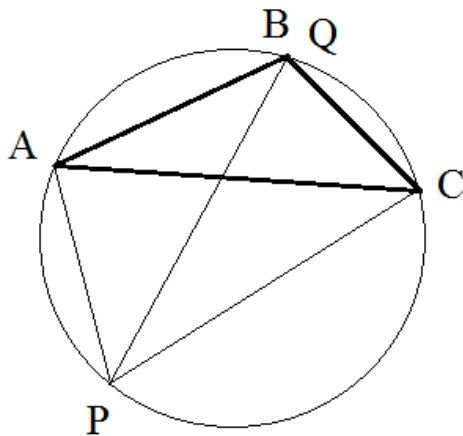


Figure 2.

determine an orientation  $\theta_{BQ}$ .

If the point P is near the circle determined by A, B, C, then the Collins' auxiliary point Q is very close to B and the orientation  $\theta_{BQ}$ , calculated from coordinates, will have very high errors.

Practical experience also shows that for other methods (Pothot-Snellius, Cassini), if the new point is near the circle or on the circle determined by points A, B and C, then the point is determined with very large errors or determining the point is even impossible.

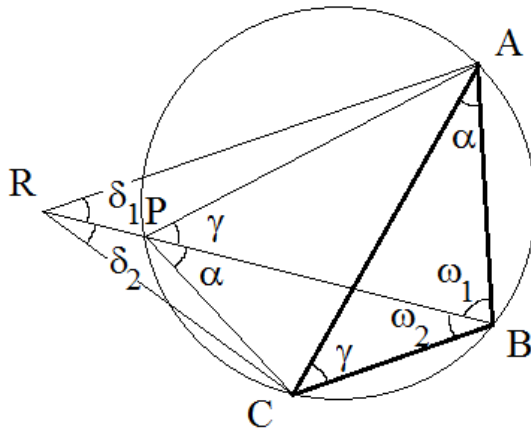
The identification of indetermination situations or those situations that lead to very high errors can be done by comparing the angles measured standing in the new point, with the angles from the triangle formed by the known points. If pairs of angles close in size are identified then the errors or results are very high.

I propose another method of determination to achieve anyway a such angular resection with good precision even in situations where other methods lead to indetermination.

### 3. THE PROPOSED METHOD

#### 3.1. The process description

Consider a situation where a R point is determined by angular resection (fig.3). The known points to which observations are made are A, B and C. These points will determine a circle circumscribed to the ABC triangle. The circumscribed circle intersects the RB direction in point P.



It can be noticed that the angles formed at point P are also found in the ABC triangle. The angles  $\delta_1, \delta_2$  are measured in R. The coordinates of points A, B, C will determine the distances AB, BC and angles  $\alpha, \beta, \gamma$ . Solving the problem lies right in determining the angles  $\omega_1$  și  $\omega_2$  after which the determination of R and P points becomes a simple problem.

Using the sinus theorem in the RPA triangle, it can be written:

Figure 3.

$$RP = PA \frac{\sin(\gamma - \delta_1)}{\sin \delta_1} \tag{3}$$

For the PAB triangle there is the relationship:

$$PA = \frac{AB \sin \omega_1}{\sin \gamma} \tag{4}$$

Replacing the relation (4) in (3) it is obtained:

$$RP = AB \frac{\sin(\gamma - \delta_1)}{\sin \gamma \sin \delta_1} \sin \omega_1 \quad (5)$$

Using a similar procedure in RPC and PCB triangles, it is obtained:

$$RP = CB \frac{\sin(\alpha - \delta_2)}{\sin \alpha \sin \delta_2} \sin \omega_2 \quad (6)$$

If the following notations are made

$$k_{AB} = AB \frac{\sin(\gamma - \delta_1)}{\sin \gamma \sin \delta_1} \quad (7)$$

$$k_{CB} = CB \frac{\sin(\alpha - \delta_2)}{\sin \alpha \sin \delta_2} \quad (8)$$

It can be seen that these coefficients are calculated from known sizes. It can also be observed that each coefficient corresponds to a known side and includes the length of that side, the measured angle that extends the side, and the angle calculated from the fixed triangle ABC that extends the same side.

The relations (5) and (6) become:

$$\begin{aligned} RP &= k_{AB} \sin \omega_1 \\ RP &= k_{CB} \sin \omega_2 \end{aligned} \quad (9)$$

It is noted that each coefficient belonging to one side is multiplied by the sine of the angle  $\omega$  adjacent to that side. Knowing that the fixed angle from point B is  $\beta$

$$\beta = \omega_1 + \omega_2 \quad (10)$$

From (9) and (10) there is obtained:

$$k_{AB} \sin \omega_1 = k_{CB} \sin (\beta - \omega_1) \quad (11)$$

The relation (11) can thus be transformed:

$$k_{AB} \sin \omega_1 = k_{CB} \sin \beta \cos \omega_1 - k_{CB} \cos \beta \sin \omega_1 \quad (12)$$

$$(k_{AB} + k_{CB} \cos \beta) \sin \omega_1 = k_{CB} \sin \beta \cos \omega_1 \quad (13)$$

Given that  $\omega_1 \neq 0$  because R, A, and B are not collinear, we divide the relation with  $\sin \omega_1$  and it is obtained:

$$(k_{AB} + k_{CB} \cos \beta) = k_{CB} \sin \beta \operatorname{ctg} \omega_1 \quad (14)$$

Or

$$\operatorname{ctg} \omega_1 = \frac{k_{AB}}{k_{CB} \sin \beta} + \operatorname{ctg} \beta \quad (15)$$

It can make the notation

$$k = \frac{k_{AB}}{k_{CB}} = \frac{AB \sin(\gamma - \delta_1) \sin \alpha \sin \delta_2}{CB \sin \gamma \sin \delta_1 \sin(\alpha - \delta_2)} \quad (16)$$

If the expressions in the fractions develop, then it is obtained

$$k = \frac{AB}{CB} \cdot \frac{\sin \gamma \cos \delta_1 \sin \alpha \sin \delta_2 - \cos \gamma \sin \delta_1 \sin \alpha \sin \delta_2}{\sin \gamma \sin \delta_1 \sin \alpha \cos \delta_2 - \sin \gamma \sin \delta_1 \cos \alpha \sin \delta_2} \quad (17)$$

Simplify the fraction with the product  $\sin \gamma \sin \delta_1 \sin \alpha \sin \delta_2$  and it is obtained:

$$k = \frac{AB}{CB} \cdot \frac{\operatorname{ctg} \delta_1 - \operatorname{ctg} \gamma}{\operatorname{ctg} \delta_2 - \operatorname{ctg} \alpha} \quad (18)$$

or

$$k = \frac{AB}{CB} \cdot \frac{n_1}{n_2} \quad (19)$$

In which:

$$\begin{aligned} n_1 &= \operatorname{ctg} \delta_1 - \operatorname{ctg} \gamma \\ n_2 &= \operatorname{ctg} \delta_2 - \operatorname{ctg} \alpha \end{aligned} \quad (20)$$

From relations (18) (16) and (15) it follows that:

$$\operatorname{ctg} \omega_1 = \frac{k}{\sin \beta} + \operatorname{ctg} \beta \quad (21)$$

Or

$$\omega_1 = \operatorname{arccctg} \left( \frac{k}{\sin \beta} + \operatorname{ctg} \beta \right) \quad (22)$$

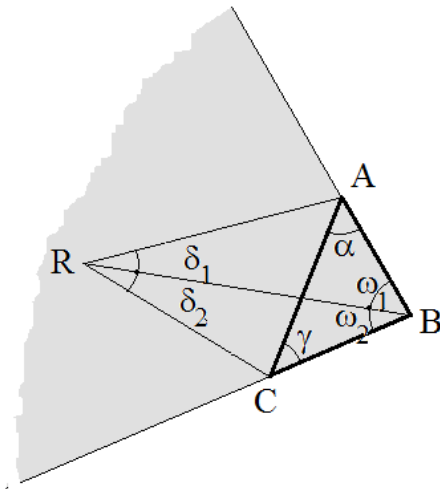
If the value obtained for the angle  $\omega_1$  is negative, it means that the angle is obtuse and  $200^\circ$  will be added to the value obtained.

$$\omega_2 = \beta - \omega_1 \quad (23)$$

### 3.2. The dependence of coefficients $n_1$ and $n_2$ on the position of the new point

The form of the coefficients  $n_1$  and  $n_2$  depends on the placement of the new point R:

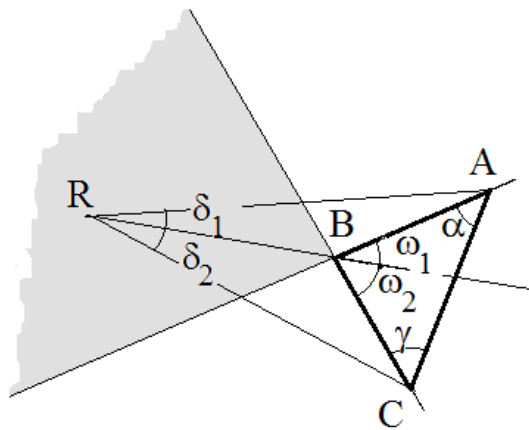
a) If the point R is within the angle B together with the AC side as in Figure 4, then the relations contain the sign "-"



$$\begin{aligned} n_1 &= \operatorname{ctg} \delta_1 - \operatorname{ctg} \gamma \\ n_2 &= \operatorname{ctg} \delta_2 - \operatorname{ctg} \alpha \end{aligned} \quad (24)$$

Figure 4.

b) If the point R is located opposite the angle B as in Figure 5 then the relations contain the sign "+"



$$\begin{aligned} n_1 &= \text{ctg } \delta_1 + \text{ctg } \gamma \\ n_2 &= \text{ctg } \delta_2 + \text{ctg } \alpha \end{aligned} \quad (25)$$

Figure 5.

### 3.3. The determination of BR distance

The calculation of this distance is also done using different formulas depending on the location of the R point:

a) If the R point is in the situation shown in Figure 4 then

$$RB = AB \frac{\sin(\omega_1 + \delta_1)}{\sin \delta_1} \quad \text{sau} \quad RB = CB \frac{\sin(\omega_2 + \delta_2)}{\sin \delta_2} \quad (26)$$

b) If the R point is in the situation shown in Figure 5 then

$$RB = AB \frac{\sin(\omega_1 - \delta_1)}{\sin \delta_1} \quad \text{sau} \quad RB = CB \frac{\sin(\omega_2 - \delta_2)}{\sin \delta_2} \quad (27)$$

### 3.4 The determination of R point coordinates

First determine the orientation  $\theta_{BR}$ . For the case of Figure 4 the orientation is:

$$\theta_{BR} = \theta_{BA} - \omega_1 \quad \text{sau} \quad \theta_{BR} = \theta_{BC} + \omega_2 \quad (28)$$

For the case of Figure 5 the orientation is:

$$\theta_{BR} = \theta_{BA} + \omega_1 \pm 200 \quad \text{sau} \quad \theta_{BR} = \theta_{BC} - \omega_2 \pm 200 \quad (29)$$

The coordinates of the R point will be:

$$\begin{aligned} x_R &= x_B + BR \cos \theta_{BR} \\ y_R &= y_B + BR \sin \theta_{BR} \end{aligned} \quad (30)$$

If on the field the operator stays at a point P on the circle circumscribed to the ABC triangle, then he will be in a state of indetermination which will be easily identified because the angles measured by the operator will be equal in magnitude to the angles formed at the A and C points of the ABC triangle.

In this undetermined situation, the operator, staying in P, will look at the point B (the middle point between A B and C) and then turning instrument's lunette into the vertical plane, will materialize a point R at a distance of a few meters. It is sufficient that the R point is only a few meters of P, even close to the circle. However, he must respect the collinearity condition with points P, B and R.

The point R is determined and then the point P can be determined using the RP distance calculated with relation (5) or (6) and orientation  $\theta_{RB}$  because the points R, P and B are collinear.

### 3.5 The $\omega_1$ angle's determination error

The orientation between the new point and an old (middle point in the proposed method) point is determined using the angle  $\omega_1$ . Therefore the precision of the orientation depends on the error with which the angle  $\omega_1$  is determined [4], [5]. In the differentiation of the relation (21) was obtained:

$$-\frac{1}{\sin^2 \omega_1} \frac{d\omega_1}{\rho''} = \frac{1}{\sin \beta} dk \quad (31)$$



After the logarithm of the relation (19) and its differentiation, it is obtained

$$\ln k = \ln AB - \ln CB + \ln n_1 - \ln n_2 \quad (32)$$

$$\rho^n \frac{dk}{k} = \frac{1}{n_1} \cdot \left( -\frac{1}{\sin^2 \delta_1} \right) d\delta_1 - \frac{1}{n_2} \cdot \left( -\frac{1}{\sin^2 \delta_2} \right) d\delta_2 \quad (33)$$

$$d\omega_1 = \frac{k \cdot \sin^2 \omega_1}{\sin \beta} \left( \frac{1}{n_1 \sin^2 \delta_1} d\delta_1 - \frac{1}{n_2 \sin^2 \delta_2} d\delta_2 \right) \quad (34)$$

The  $\omega_1$  angle's determination error is:

$$m_{\omega_1} = \pm \frac{k \cdot \sin^2 \omega_1}{\sin \beta} \sqrt{\left( \frac{1}{n_1 \sin^2 \delta_1} \right)^2 m_{\delta_1}^2 + \left( \frac{1}{n_2 \sin^2 \delta_2} \right)^2 m_{\delta_2}^2} \quad (35)$$

And if it is considered  $m_{\delta_1} = m_{\delta_2} = m_\delta$  then

$$m_{\omega_1} = \pm \frac{k \cdot \sin^2 \omega_1}{\sin \beta} m_\delta \sqrt{\left( \frac{1}{n_1 \sin^2 \delta_1} \right)^2 + \left( \frac{1}{n_2 \sin^2 \delta_2} \right)^2} \quad (36)$$

#### 4. CONCLUSIONS

The proposed variant provides solutions for the angular resections where other methods would lead to indetermination or when very high errors occur due to the fact that the new point is close to the circle determined by known fixed points.

The proposed variant is also valid for points away from the outside of the circle but also for points inside the circle.

The accuracy of determining the orientation  $\theta_{BR}$  and implicitly of the point R, is superior to other methods because the orientation is determined by the geometric elements of the triangles well placed in space and without using the coordinates of very close points.

**REFERENCES**

- [1] Schofield W., Breach M., *Engineering Surveying*, Published by Elsevier Ltd, London, 2007
- [2] Bruce R. Harvey, *Survey computations*, UNSW Sydney, 2012
- [3] Dima N. ș.a. *Topografie generală si elemente de topografie minieră*, Ed. Universitas, Petroșani, 2005
- [4] Dima N., Herbei O., Vereș I., *Teoria erorilor și metoda celor mai mici pătrate*, Ed. Universitas, Petroșani 1999.
- [5] Vereș I., *Evaluarea calității lucrărilor topografice și geodezice*, Editura Universitas Petroșani, 2017
- [6] Vereș I., Filip L. - *The analysis of geodetical bases used in achievement of underground mining works*, Proceedings of 14th SGEM GeoConference on Informatics, Geoinformatics and Remote Sensing, Albena, 2014

Scientific Reviewer:  
Prof. PhD. Eng. Nicolae DIMA

## PERFORMING SOME ANALYSIS ON DEM USING THE SURFER SOFTWARE

DACIAN-PAUL MARIAN <sup>1</sup>  
RAMONA-RAFILA MARIAN <sup>2</sup>

**Abstract:** *A DEM or Digital Elevation Model is a 3D representation of the surface realized from elevation data. The DEM has been widely applied in various domains such us: surveying for various surface analysis, hydrology for water flow, mass movement for landslides or avalanches, in civil engineering for designing different constructions and other. This paper shows how to perform some analyzes on DEM using the Surfer software.*

**Keywords:** map, DEM, surface, analysis, watershed, profile

### 1. GENERALITIES

Technological development in terms of data acquisition in the surveying field, led to the realization of digital models of the terrestrial surface of outstanding quality. When talking about the digital model of the terrestrial surface we're dealing with three types of elevation models: DSM (Digital Surface Model), DEM (Digital Elevation Model) and DTM (Digital Terrain Model) [3].

A DSM is a 3D representation of the surface with all the objects on it (either natural - such as trees - or artificial, buildings, bridges etc.).

A DEM is a 3D representation of the surface in which all the objects on it are removed. DEM data files contain the elevation of the terrain over a specific area, usually at a fixed grid interval over the surface.

A DTM is a 3D representation of the surface consisting of X, Y and Z coordinates stored in a digital form. It includes not only heights and elevations but other geographical elements and natural features such as rivers, ridge lines, etc. A DTM is effectively a DEM that has been augmented by elements such as breaklines and observation other than the original data to correct for artifacts produced by using only the original data [1].

With the increasing use of computers in engineering and the development of fast three-dimensional computer graphics the digital models of the terrestrial surface is

---

<sup>1</sup> Min. Eng. Lecturer Ph.D. at the University of Petroșani

<sup>2</sup> Min. Eng. Ph.D. Student at the University of Petroșani

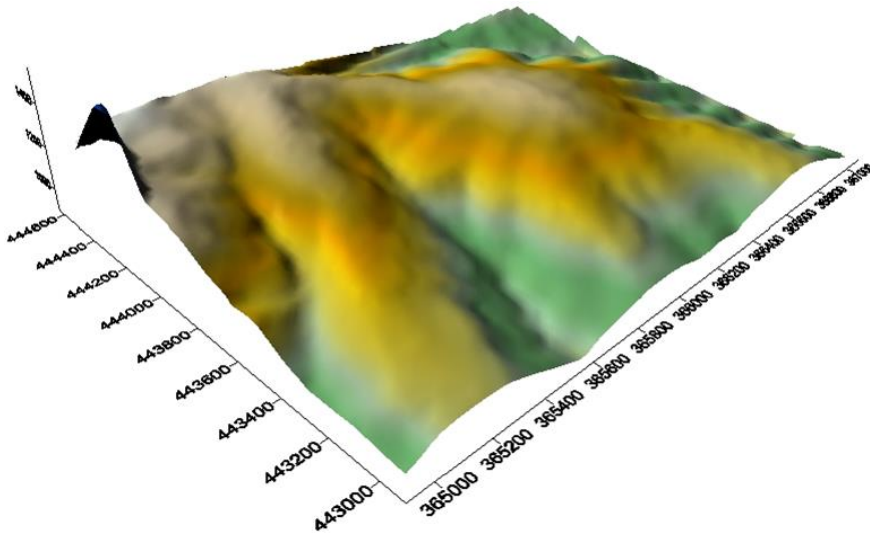
becoming a powerful tool for a great number of applications in the earth and the engineering sciences.

## 2. SURFACE ANALYSIS ON DEM USING SURFER

Surfer is a powerful contouring, gridding and surface mapping package for scientists, engineers, educators or anyone who need to generate maps quickly and easily, registered trademark of Golden Software, LLC. Surfer is a grid-based mapping program that interpolates irregularly spaced XYZ data into a regularly spaced grid. The grid is used to produce different types of maps including contour, color relief and 3D surface maps [2].

Multiple analyzes can be performed with this program using a DEM, among which: Watershed analyze, creating a profile (or cross section), area and volume calculation, Line of Sight analyze, View Sherd analyze etc. [4], [5], [6].

To illustrate how to perform these analyzes a DEM was generated (Fig. 1).



**Figure 1.** Digital Elevation Model

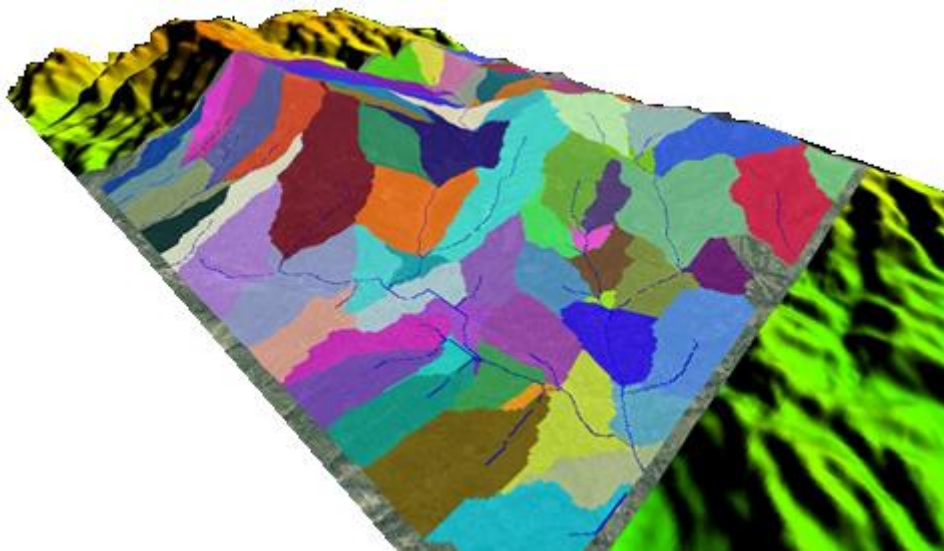
### 2.1. Watershed analyze

A watershed is defined as the region draining into a stream, stream system or body of water. This shows the path water will take across the grid [2].

To perform an analysis of this type is accessed Watershed command, from Home / New Map / Speciality / Watershed, then is chosen the desired grid after which the map is automatically created. The resulted map is represented in figures 2 and 3.



**Figure 2.** Watershed map



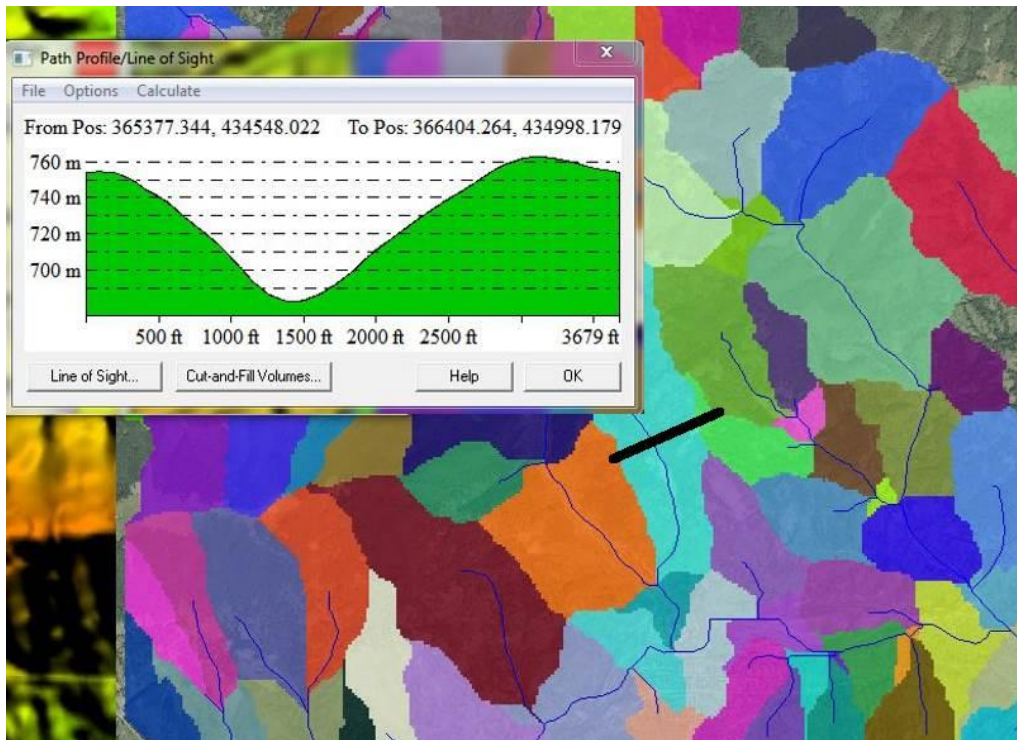
**Figure 3.** Watershed map – 3D representation

The blue lines are the water collection basin (stream lines) and the colored regions represent the areas from which water is collected.

## 2.2. Creating a profile

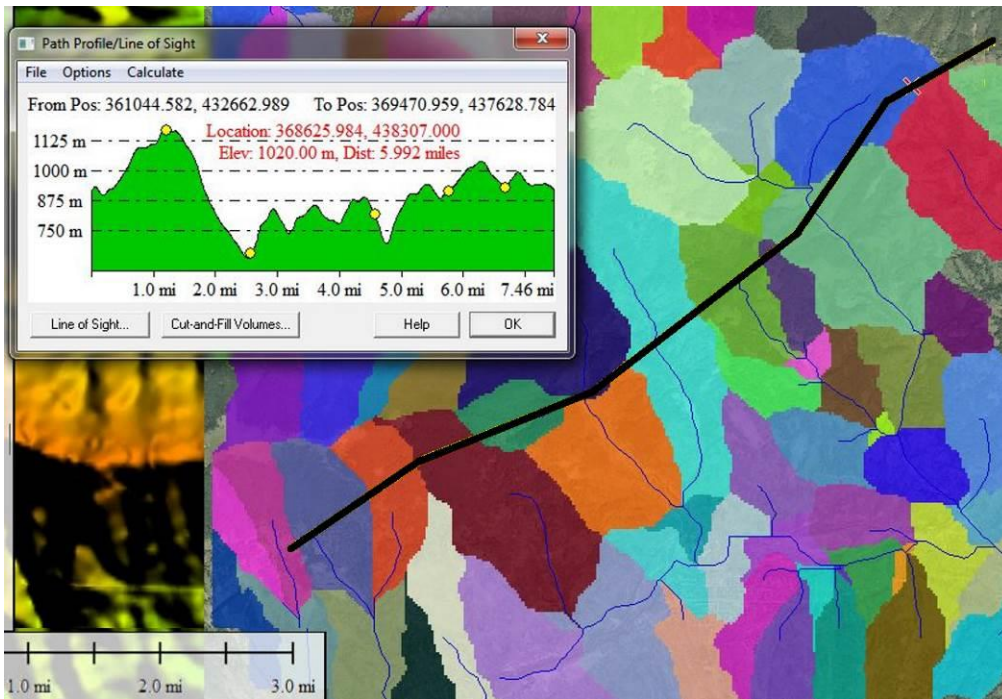
Based on DEM, profiles can be generated or multiple profiles can be combined to display a cross section.

In order to create a profile, the Profile command must be chosen, from Map Tools / Add to Map / Profile, and the line that defines the profile must be drawn. After clicking the Enter key the profile graph is automatically created (Fig. 4).



**Figure 4.** Drawing profiles along a straight line

Profiles can be generated after a straight segment or after a polyline (selecting all the points that define that polyline – fig. 5)



**Figure 5.** Drawing profiles after a polyline

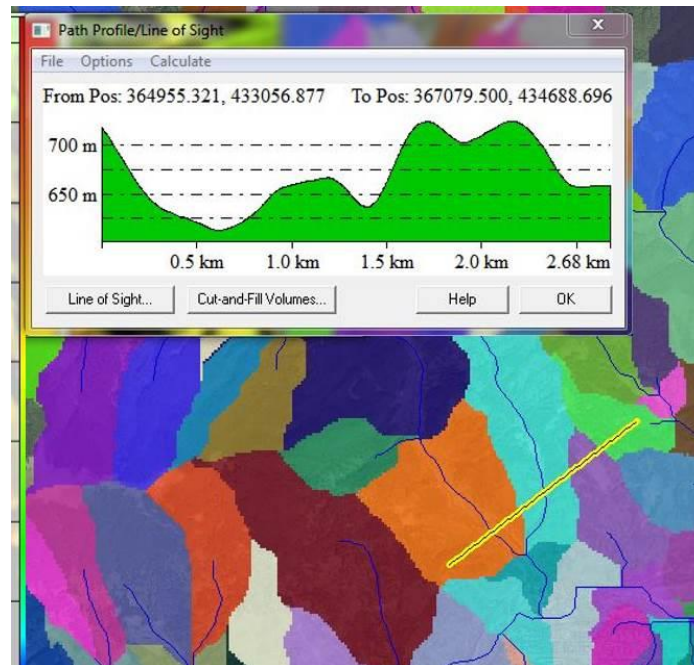
Based on the created profile, two more analyzes can be made (as can be seen from figures 4 and 5) namely: Cut and Fill Volumes and Line of Sight.

Cut and Fill Volumes analyze displays the Positive Volume (Cut) and the Negative Volume (Fill).

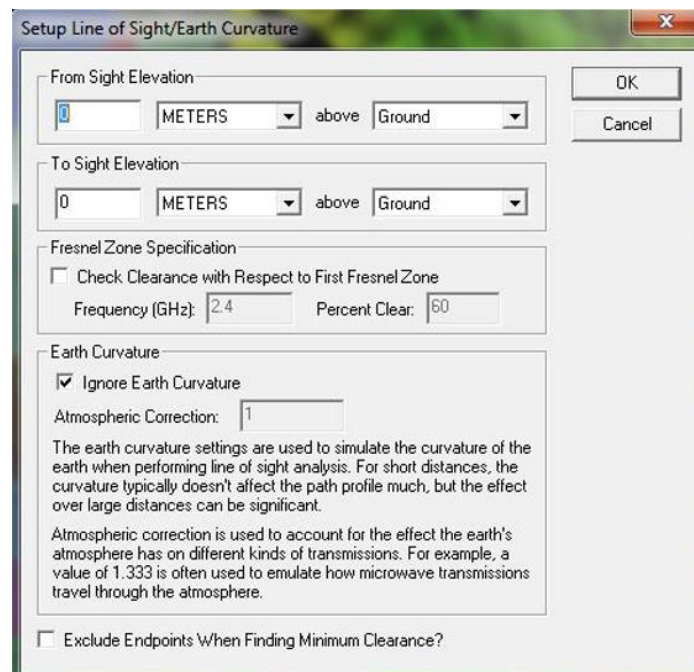
### **2.3. Line of Sight analyze**

On the created profile can be analyzed the visibility between two points. This analysis is very useful in planning topographical measurements as well as when installing certain objectives that require good visibility between them (e.g. radio antennas).

To perform this analysis, select the line that joins the two points and then specify the height from the ground level at which the two points are located (Fig. 6-8).

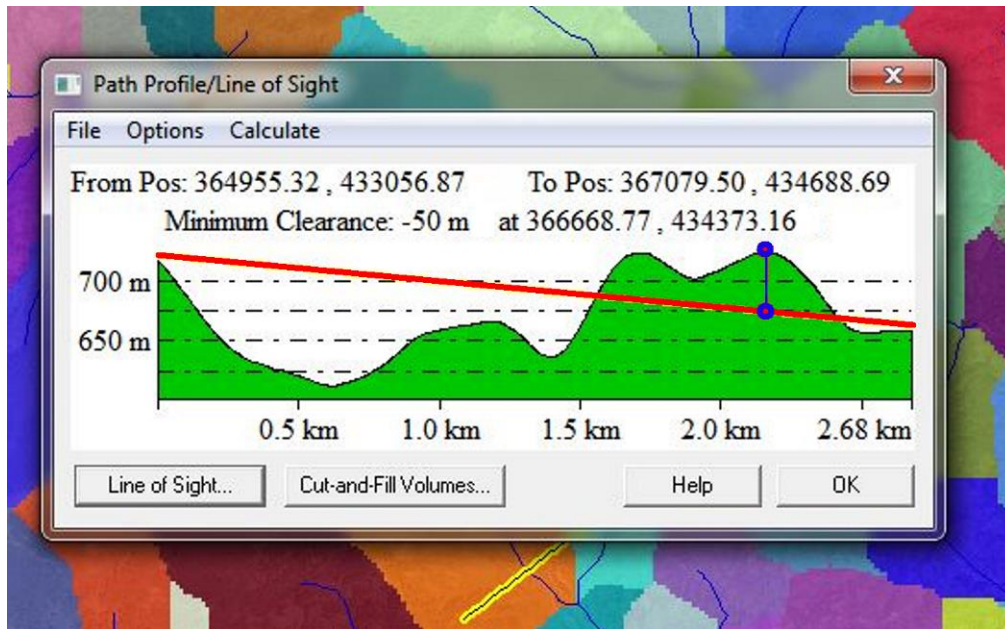


**Figure 6.** Line of Sight analyze



**Figure 7.** Choosing the high of the objectives above ground





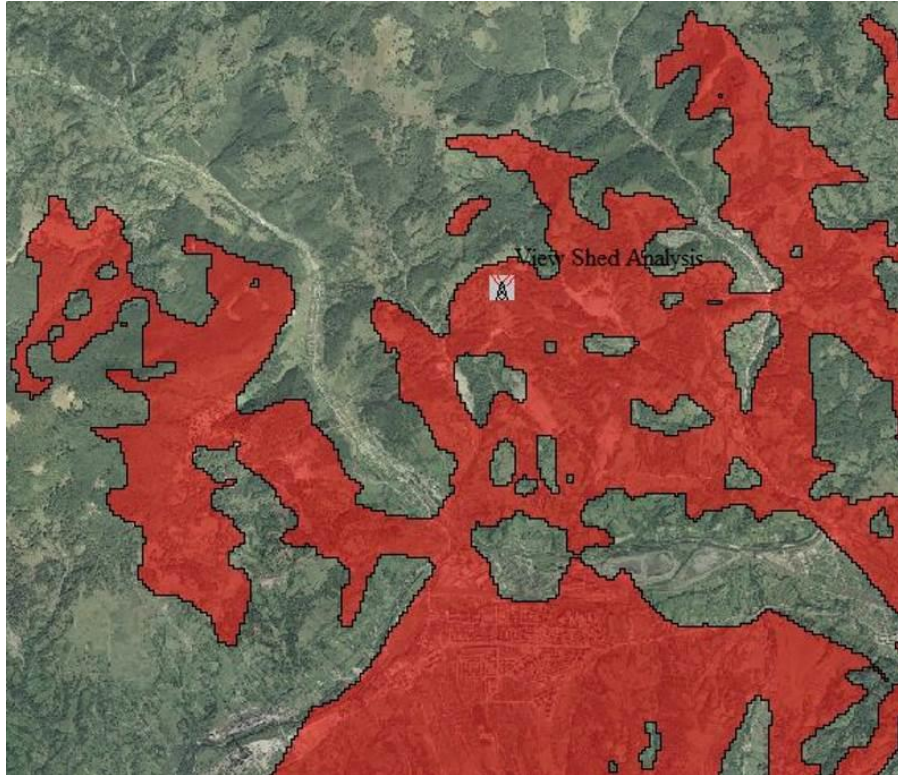
**Figure 8.** The results of the Line of Sight analyze

As a result of the analysis, it can be observed that in the analyzed case, the visual field is obstructed at a maximum height of 50m, at the specified coordinates.

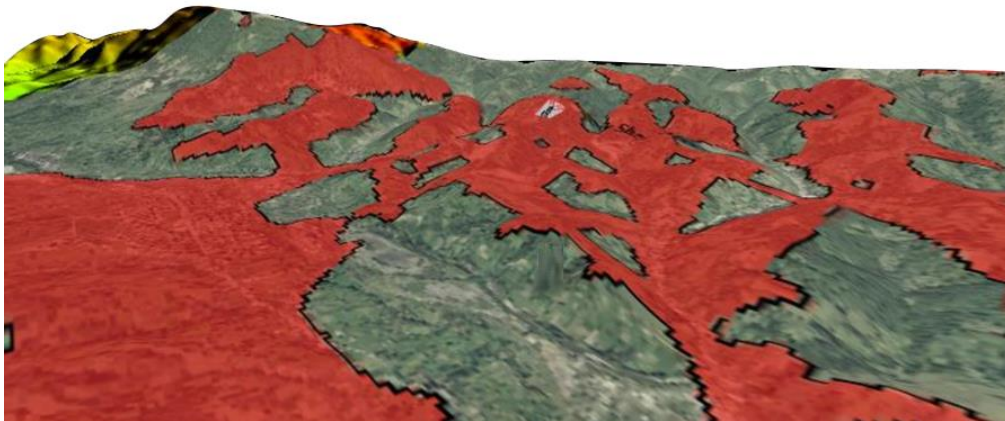
#### **2.4. Viewshed analyze**

This analyze indicates which grid cells are visible from an observer's or transmitter's location [2]. The viewshed analyze has known a large applicability in different fields of activity, among the most popular applications being: to the construction of certain towers or transmitter/receiver antennas, the estimation of the impact of the construction of a large building in a certain area, to determine the visibility of certain tourist attractions etc.

To perform this analysis is accessed the command Viewshed, from Home / Add Map / Layer / Viewshed, after which a grid and a transmitter location are required. As a result of this analysis, the visible areas from the chosen location (from the selected point) will be marked with a transparent color (in our case red – figures 9 and 10).



**Figure 9.** The results of the Viewshed analyze, 2D representation



**Figure 10.** The results of the Viewshed analyze, 3D representation

### 3. CONCLUSIONS

Through computers, the representation of the terrestrial surface has experienced a spectacular development, this offering multiple opportunities for later use of plans and maps.

With the help of digital maps, the design of different objectives on the terrestrial surface has been greatly facilitated. Also, the execution time of a particular project has been greatly reduced and the precision has increased due to the reduction of human errors.

In this paper were presented some analyzes that can be made on the Digital Elevation Model, useful analyzes in different fields of activity.

### REFERENCES

- [1]. <http://www.gisresources.com/confused-dem-dtm-dsm/>.
- [2]. <http://downloads.goldensoftware.com/guides/Surfer15UsersGuidePreview.pdf>
- [3]. [http://en.wikipedia.org/wiki/Digital\\_elevation\\_model](http://en.wikipedia.org/wiki/Digital_elevation_model)
- [4]. Marian D.P. - *Întocmirea planurilor topografice*, Editura Universitas, Petroșani, 2016.
- [5]. Marian D.P. – *Surveying and 3D modeling of a natural underground cavity. Nandru cave, Hunedoara County*, Recent Advances in Geodesy and Geomatics Engineering WSEAS, 2013.
- [6]. Vereș I. – *Automatizarea lucrărilor topo-geodezice*, Editura Universitas, Petroșani, 2006.

Scientific Reviewer:  
Assoc. Prof. PhD. Eng. Ioel VEREȘ

**INDEX OF AUTHORS**

<b>A</b>	<b>F</b>	<b>P</b>
Andraș I. - 47	Faur F. - 47, 60	Petre I. - 12
Apostu (Nyari) I.M. - 60	Fechet R.M. - 4, 12	
<b>B</b>	<b>G</b>	<b>R</b>
Boantă C. - 31	Georgescu M. - 124	Rădoi F. - 22
	Gherghe I. - 31, 37	
<b>C</b>	<b>L</b>	<b>T</b>
Chiuzan E. - 31	Lazăr M. - 47, 60	Tomescu C. - 31
Cioclea D. - 31		
<b>D</b>	<b>M</b>	<b>V</b>
Deak Ș.E. - 4, 12	Matei A. - 31	Vereș I. - 83
	Marian D.P. - 93	
	Marian R.R. - 70, 93	
	Moanță A. - 12	

## INSTRUCTIONS FOR AUTHORS<sup>1</sup>

**THE TITLE OF THE PAPER WILL BE WRITTEN WITH CAPITAL LETTERS, CENTERED, AT 7.0 cm FROM THE UPPER EDGE OF A4 FORMAT, ALONG THE ENTIRE WIDTH, TIMES NEW ROMAN, 14 POINTS, BOLD.**

· (14 points)

· (14 points)

**The first name and the family name will be written with CAPITAL LETTERS, BOLD, CENTERED, 130 mm width, Times New Roman, 12 points, each name being followed by number, and in the footnote the didactic and scientific degree, the position and place of work of the authors (possibly fax, E-mail) are indicated, with italics, 130 mm width, Times New Roman, 11 points.**

· (12 points)

· (12 points)

**<Tab> Abstract: (Times New Roman, 10 points, bold)** The Abstract will only be in English and will have between 50 and 100 words, arranged all over the entire width, single, left – right alignment, all over the width of the printed space, Times New Roman, 10 points.

· (10 points)

· (10 points)

**<Tab> Key words: (Times New Roman, 10 points, bold)** 5 – 10 words, in English, along the entire width, Times New Roman, 10 points.

· (10 points)

· (10 points)

· (10 points)

**<Tab> 1. THE TITLE OF THE CHAPTER IS WRITTEN WITH CAPITAL LETTERS, BOLD, TIMES NEW ROMAN, 11 POINTS AND WILL BE NUMBERED WITH ARABIC NUMBERS.**

· (11 points)

**<Tab>** The paper text paragraphs will be left – right aligned. The lines of the entire text will be single spaced with Times New Roman fonts, size 11 points.

The paper will be edited in a language of international circulation (English, French, German) on A4 format (210 x 297), page setup: top 5,6 cm, bottom 4,6 cm, left 3,7 cm, right 3,7 cm, in WORD or WORDPERFET or WINDOWS and the number of pages must be even between 4 and 16. The size of the symbol is given next and is written in the instructions used to assist in editing the text. It indicates a blank line and does not show in the text of the paper, being obtained by pressing <ENTER>. The size of a <Tab> is 1,27 cm. No blank line is left between the paragraphs. Between the last line before the title and the title of the chapter and between the title and the first next line a blank line is left for each.

---

<sup>1</sup> Professor Eng., Ph.D. at the University of Petroșani, adresa email

<Tab> **1.1 Subchapter. Subchapters can be used in the text, numbered with the number of the chapter and a number showing the number of the subtitle within the chapter. The subchapters and the numbers are Times New Roman, 11 points, bold.**

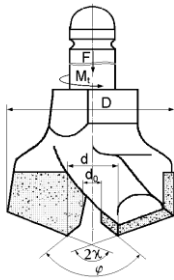
· (11 points)

The text is written in new paragraph and not continuing the subtitle, an 11 point blank line being left between the subtitle and the following text.

· (11 points)

## **2. PRESENTATION OF THE FIGURES**

· (11 points)



**Fig. 1.** Detachable bit

Figures should be enclosed in the text in the order of their presentation, as far as possible on the page where reference is made to them. They shall be numbered with Arabic numbers. Black – and – white, high contrast figures are recommended. Photos can be used as well, but they should be of good quality, clarity and sufficient contrast. The figures will have a legend (name of the figure), which, along with the number, will be written underneath with Times New Roman, 10 points, centered as to the figure. The figures will be surrounded by text.

· (11 points)

## **3. PRESENTATION OF THE TABLES**

· (11 points)

The tables will be enclosed in the text, a 10 points blank line being left above and under the table, and will be numbered with Arabic numbers. Both the number and the explanations to the table are written with Times New Roman, 10 points, italic, for the number and bold for the explanation to the table, centered in the space of the table and above it. The table entries will be Times New Roman, 10 points, bold, and the data in the table will be Times New Roman, 10 points. The thin lines of the table will be ½ points (0,02 cm), and the thick ones will be ¾ ... 1 points (0,03 ... 0,04 cm).

· (11 points)

## **4. PRESENTATION OF THE MATHEMATICAL EQUATIONS**

· (11 points)

The mathematical equations will be with times New Roman, 11 points, center of the page and numbered on the right with Arabic numbers between round brackets.

· (8 points) <Blank line 8 point high>

$$X^2 + Y^2 = Z^2 \quad (1)$$

· (8 points) <Blank line 8 point high>

An 8 point high blank line is left between the last line before the relation and the relation and between the latter and the next first line.

The last page will be at least 2/3 full.

The pages of the paper will only be numbered by a pencil outside the printing space.

· (11 points)

**REFERENCES** (will be written according to the model, Times New Roman 10 points).

· (10 points)

Marian I., *Mecanizarea în minieră*, Editura Tehnică, București, 1969.

**SCIENTIFIC REVIEWERS**

*Commission reviewers for article in the journal „Annals of the University of Petroșani Mining Engineering”*

**FIELDS OF COMPETENCE**✓ **MINING ENGINEERING:**

Prof. PhD. Eng. Dumitru FODOR - University of Petroșani  
Prof. PhD. Eng. Eugen COZMA - University of Petroșani  
Prof. PhD. Eng. Iosif ANDRAȘ - University of Petroșani

✓ **MINING SURVEYING:**

Prof. PhD. Eng. Nicolae DIMA - University of Petroșani  
Prof. PhD. Eng. Mircea ORTELECAN - U.S.A.M.V. Cluj Napoca  
Assoc.Prof. PhD. Eng. Ioel VEREȘ - University of Petroșani

✓ **MANAGEMENT IN MINING**

Prof. PhD. Eng. Florian BUȘE - University of Petroșani

✓ **ENGINEERING AN ENVIRONMENTAL PROTECTION:**

Prof. PhD. Eng. Mircea GEORGESCU - University of Petroșani  
Prof. PhD. Eng. Ioan DUMITRESCU - University of Petroșani  
Prof. PhD. Eng. Maria LAZĂR - University of Petroșani  
Assoc. Prof. PhD. Eng. Emilia DUNCA

✓ **MINE CONSTRUCTION:**

Prof. PhD. Eng. Constantin SEMEN - University of Petroșani  
Assoc.Prof. PhD. Eng. Mihaela TODERAȘ - University of Petroșani

✓ **VENTILATION AN MINE SAFETY:**

Prof. PhD. Eng. Nicolae BĂNCILĂ - University of Petroșani  
Assoc.Prof. PhD. Eng. Roland MORARU - University of Petroșani

✓ **PROCESSING OF MINERAL RESOURCES:**

Prof. PhD. Eng. Sanda KRAUSZ - University of Petroșani  
Assoc.Prof. PhD. Eng. Nicolae CRISTEA - University of Petroșani

✓ **MINING GEOLOGY**

Assoc.Prof.PhD. Laura COMĂNESCU - Universitatea din București  
Prof. PhD.Eng. Grigore BUIA - University of Petroșani

✓ **ROCK ENGINEERING**

Prof. PhD.Eng. Victor ARAD - University of Petroșani  
Prof. PhD.Eng. Ioan BUD - University of Petroșani